

- (F) Commande rotative débrochable
HX 231
- (GB) Ext. rotary handle
HX 231
- (D) Drehantrieb Türeinbau
HX 231
- (I) Comandi rotativi rinviati
HX 231
- (E) Mandos rotativos embrague
HX 231

Notice d'instructions

User instructions

Montageanleitung

Istruzioni di montaggio

Instrucciones de uso

Range H160, H250

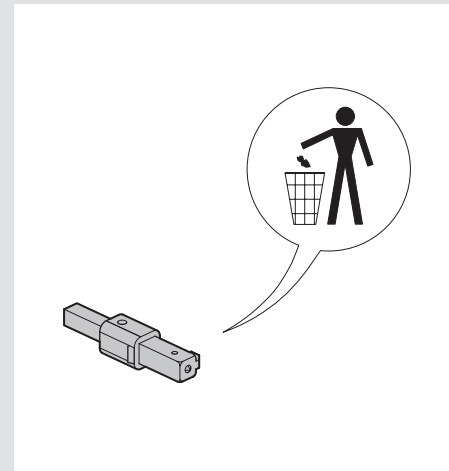
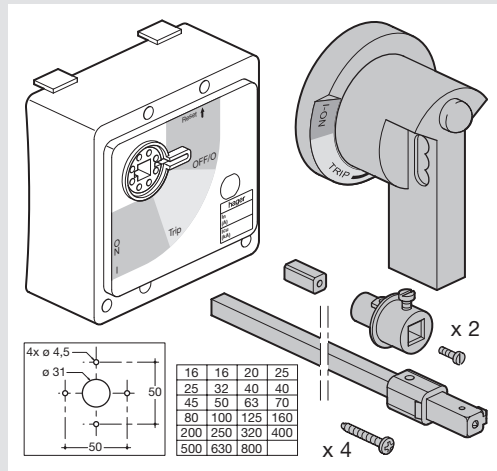
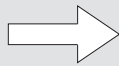
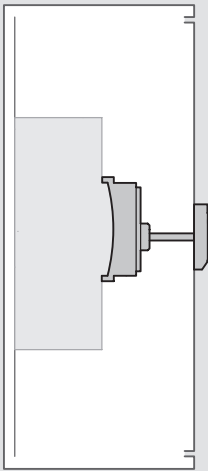
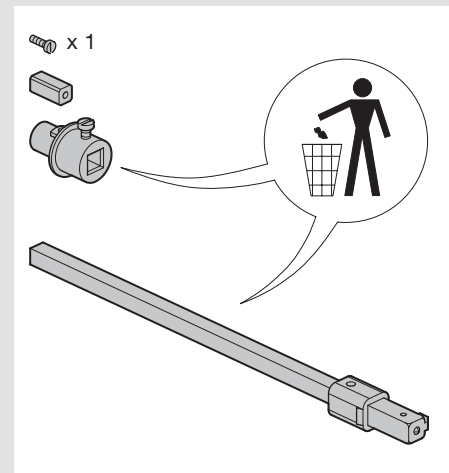
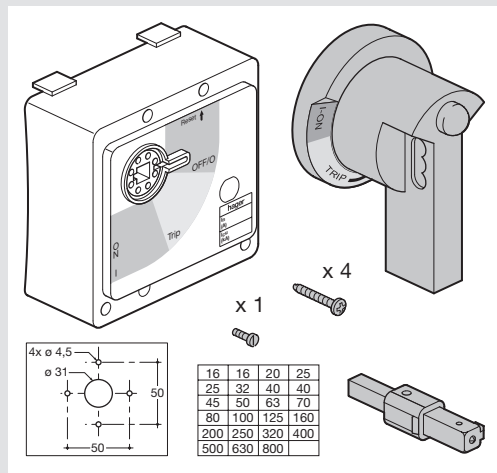
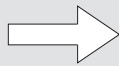
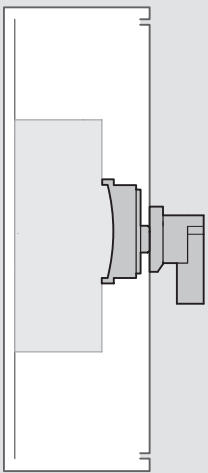
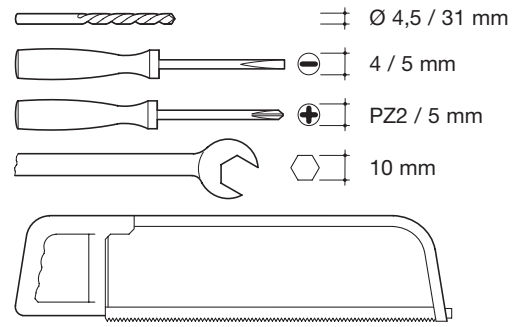
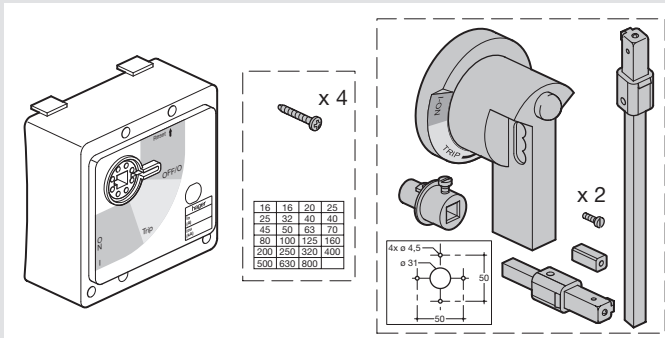

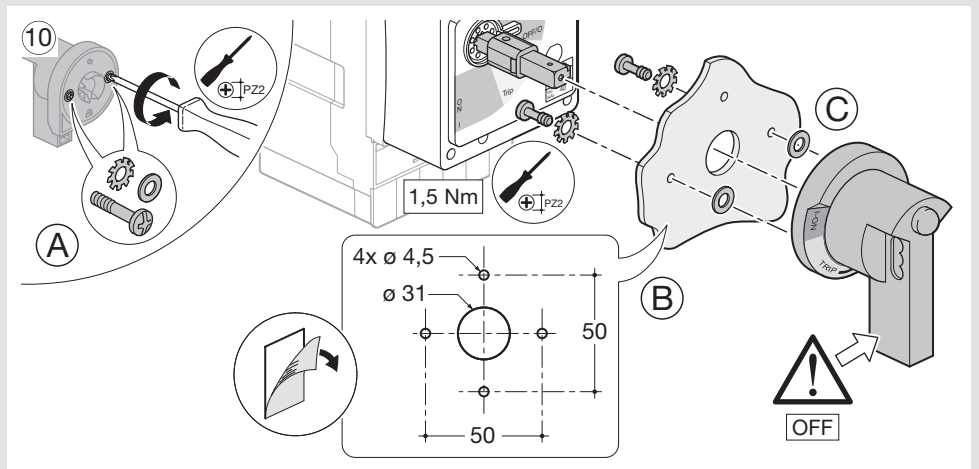
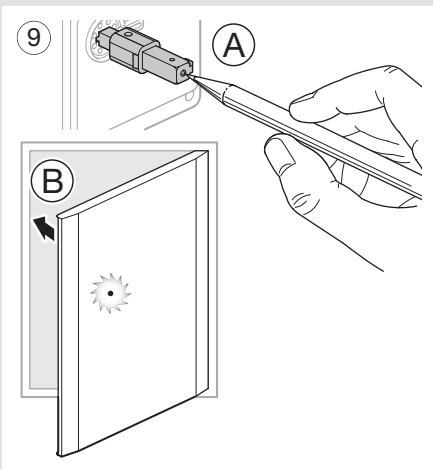
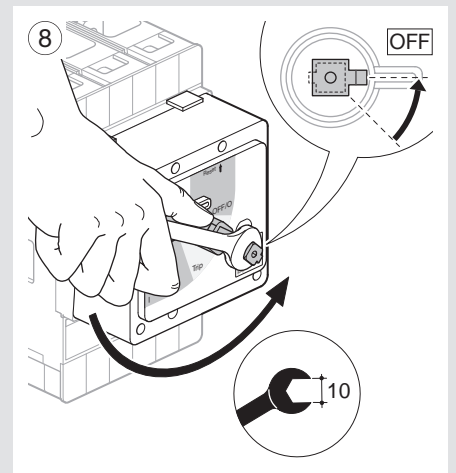
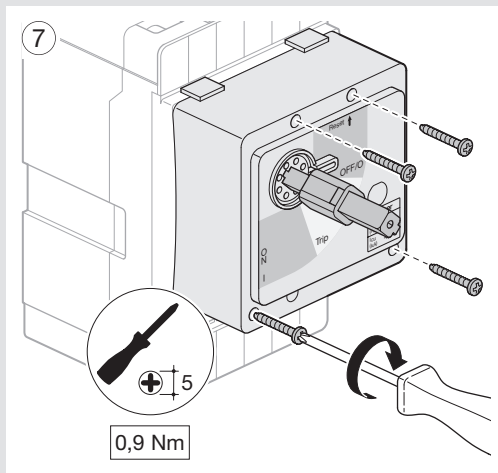
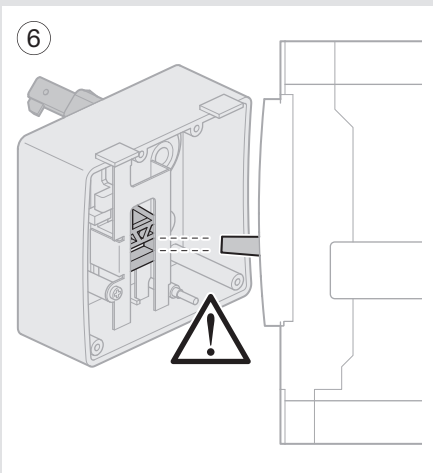
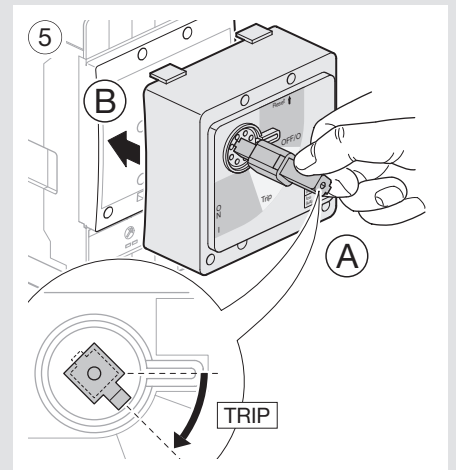
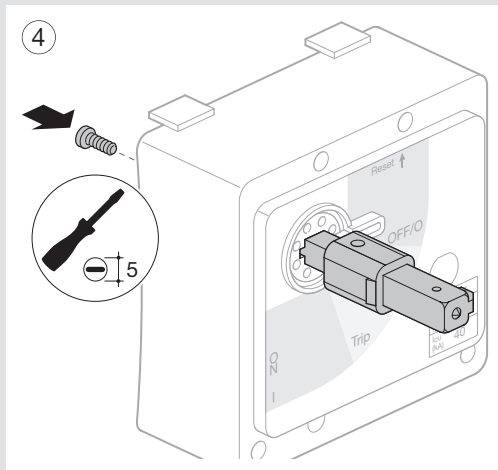
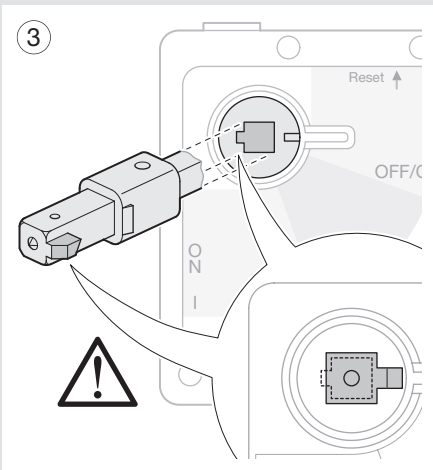
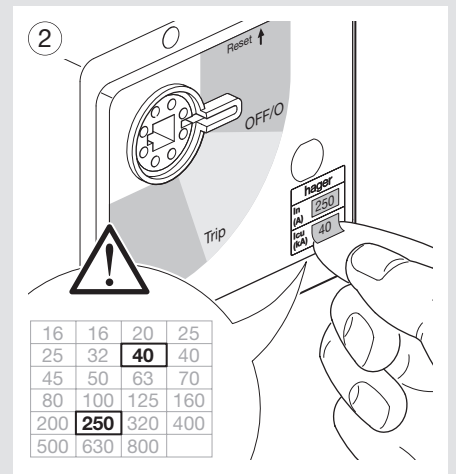
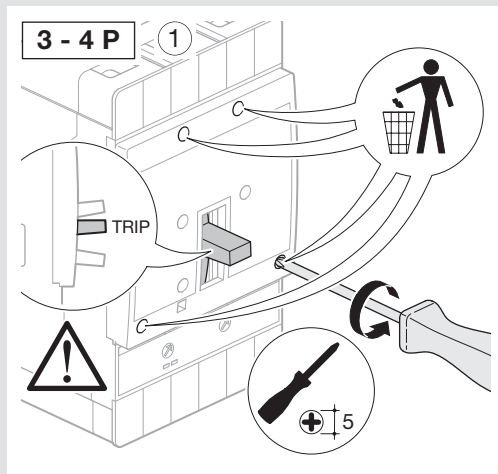
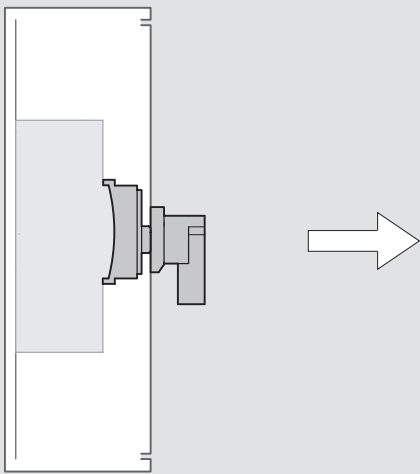

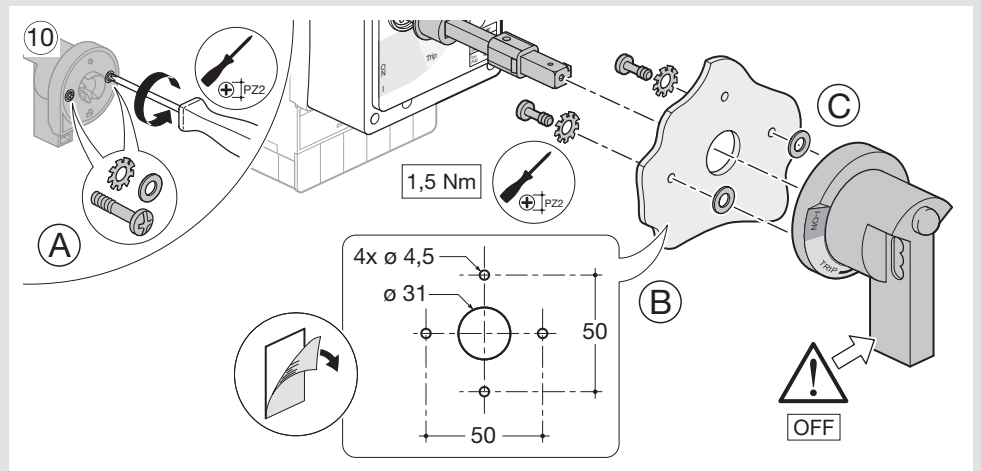
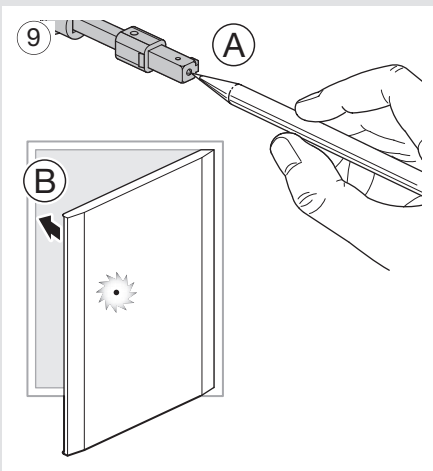
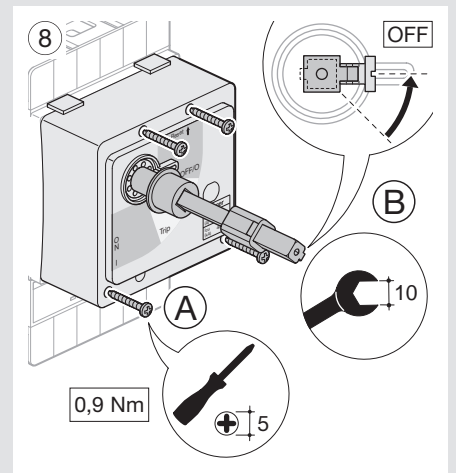
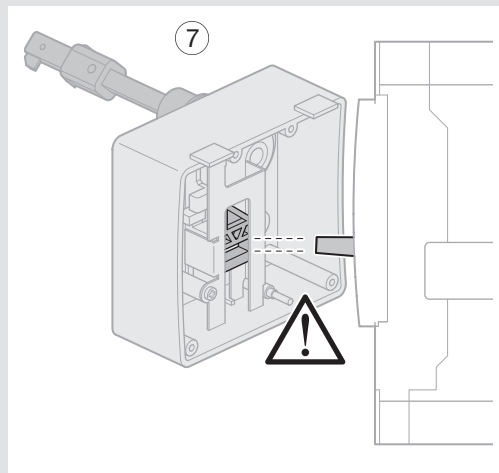
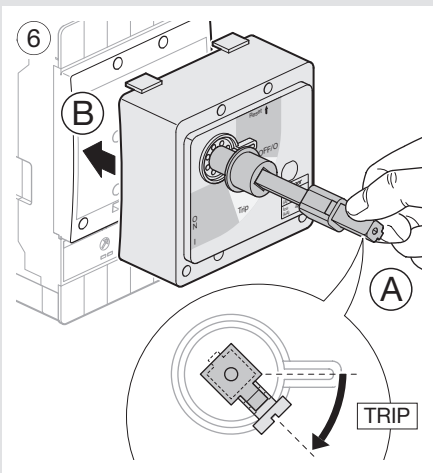
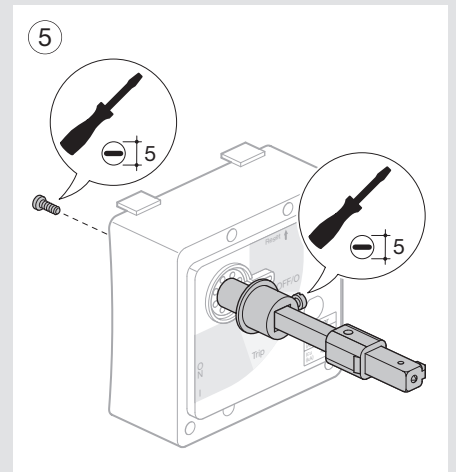
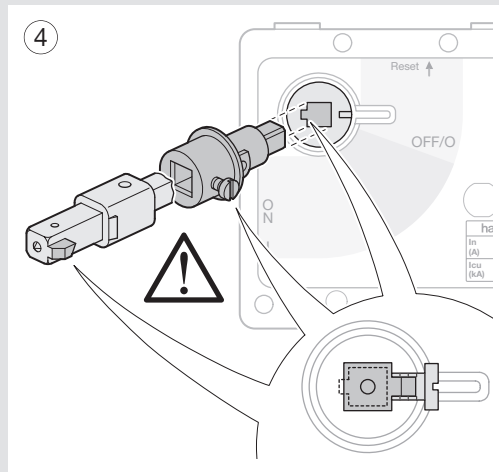
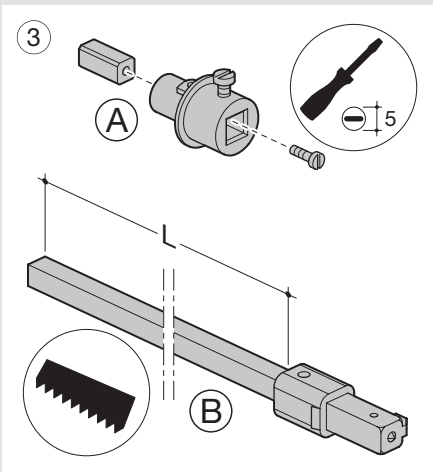
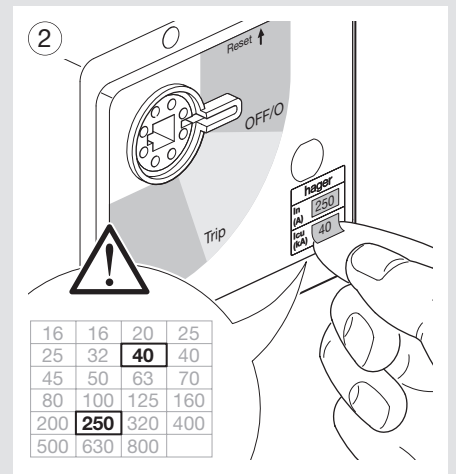
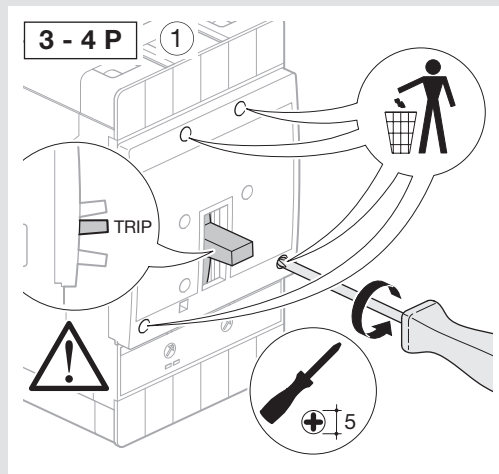
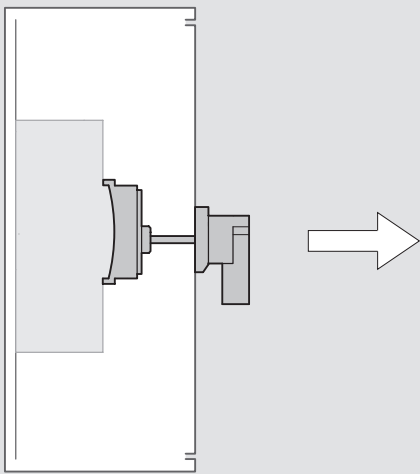

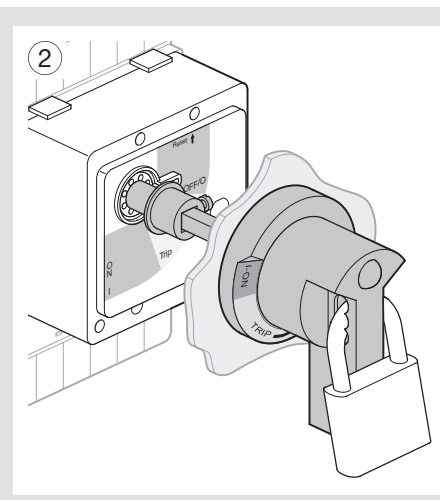
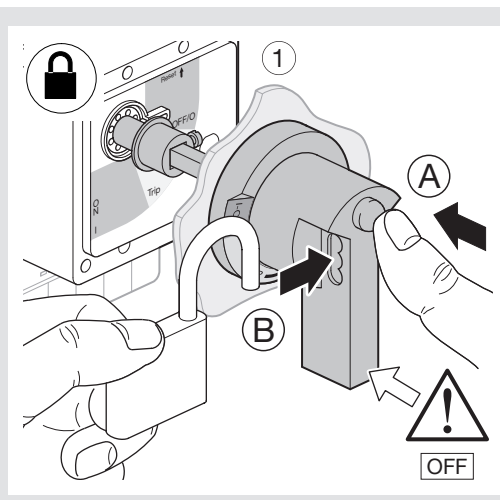
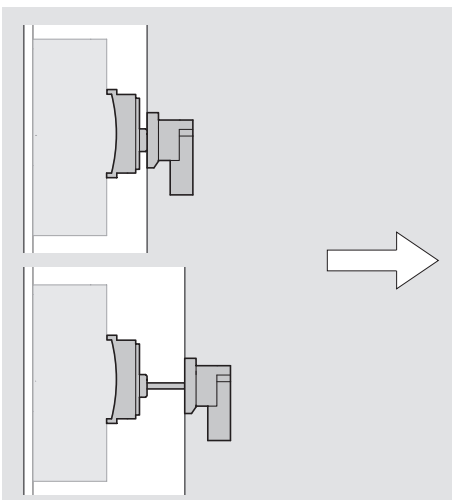
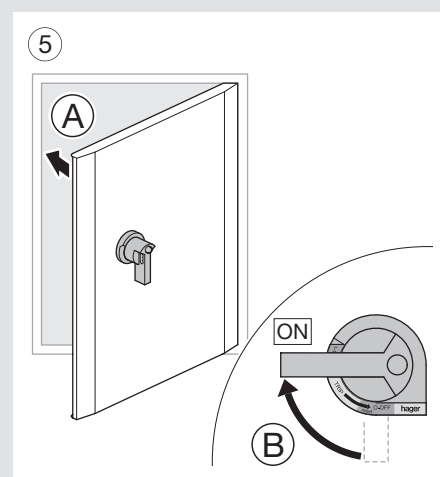
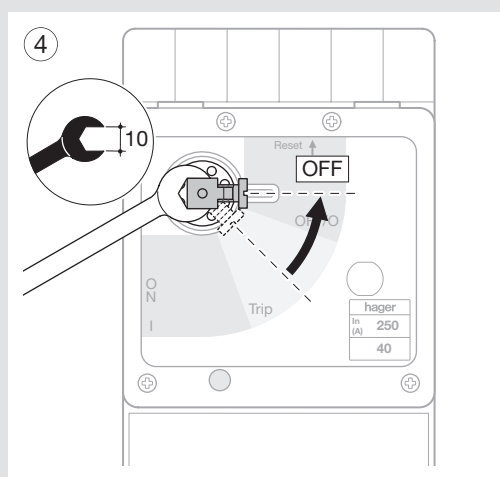
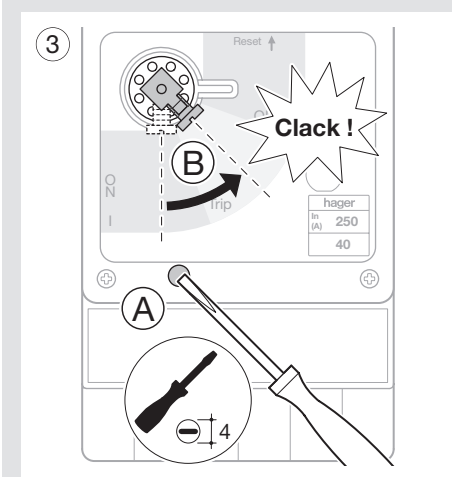
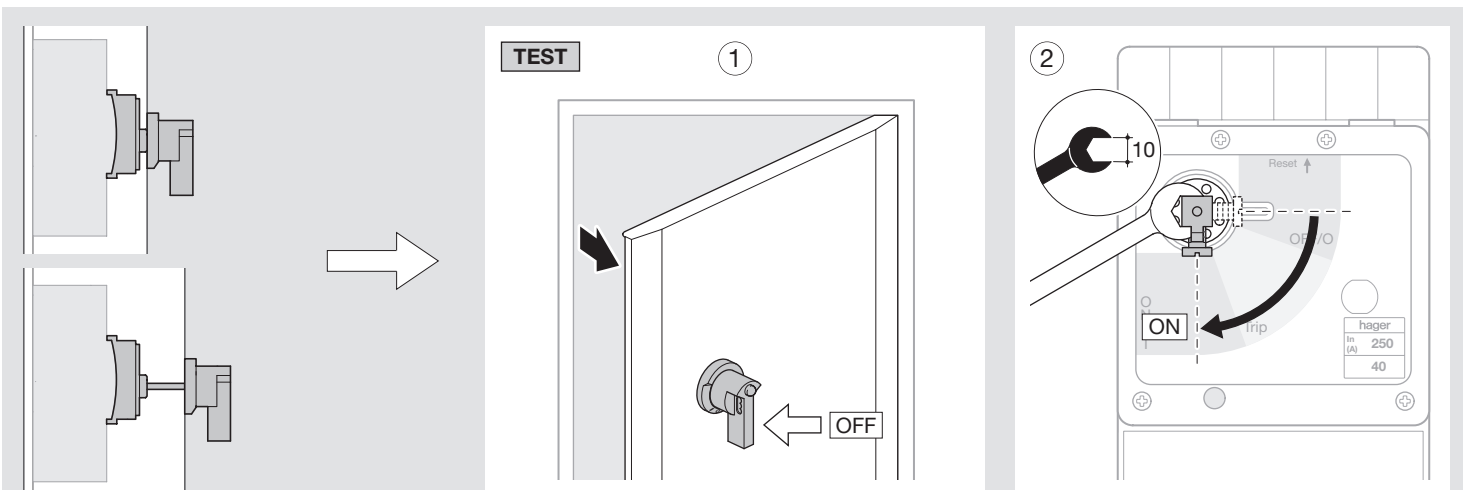

F Garantie

24 mois contre tous vices de matières ou de fabrication, à partir de leur date de production. En cas de défectuosité, le produit doit être remis au grossiste habituel. La garantie ne joue que si la procédure de retour via l'installateur et le grossiste est respectée et si après expertise notre service contrôle qualité ne détecte pas un défaut dû à une mise en œuvre et/ou une utilisation non conforme aux règles de l'art. Les remarques éventuelles expliquant la défectuosité devront accompagner le produit.

D Garantie

Es gelten die Allgemeinen Geschäftsbedingungen der Hager Electro GmbH. bzw. die gesetzliche Regelung.

I Garanzia

24 mesi contro tutti i vizi di materiale o di fabbricazione, a partire dalla data di produzione. In caso di difetti, il prodotto deve essere restituito al grossista abituale. La garanzia ha valore solo se viene rispettata la procedura di reso tramite installatore e grossista e se dopo la verifica del nostro servizio controllo qualità non vengono rincontrati difetti dovuti ad una messa in opera e/o ad una utilizzazione non conforme alle regole dell'arte. Le eventuali note esplicative del difetto dovranno accompagnare il prodotto.

GB Warranty

A warranty period of 24 months is offered on hager products, from date of manufacture, relating to any material of manufacturing defect. If any product is found to be defective it must be returned via the installer and supplier (wholesaler).

The warranty is withdrawn if :

- after inspection by hager quality control dept the device is found to have been installed in a manner which is contrary to IEE wiring regulations and accepted practice within the industry at the time of installation.
 - the procedure for the return of goods has not been followed.
- Explanation of defect must be included when returning goods.

E Garantía

24 meses a partir de la fecha de fabricación contra todo defecto de fabricación o de los materiales.

En caso de un aparato defectuoso, el material deberá ser remitido a su almacén habitual. La garantía no será válida si el retorno no se efectúa a través del almacén que ha realizado la venta, si nuestro servicio de control de calidad detecta una mala puesta en funcionamiento o una mala utilización del aparato. El aparato deberá ser acompañado de un informe explicando la defectuosidad.