

- (F) Commande rotative **HX 230**
- (GB) Rotary handle **HX 230**
- (D) Drehantrieb **HX 230**
- (I) Comandi rotativi **HX 230**
- (E) Mandos rotativos **HX 230**
- (NL) Draaibediening **HX 230**
- (P) Comando rotativo **HX 230**
- (N) Vrihåndtak **HX 230**
- (GR) Περιστροφικό χειριστήριο **HX 230**

- Notice d'instructions
- User instructions
- Montageanleitung
- Istruzioni di montaggio
- Instrucciones de uso
- Gebruiksaanwijzing
- Instruções de instalação
- Bruksanvisning
- Οδηγίες χρήσεως

Range H160, H250

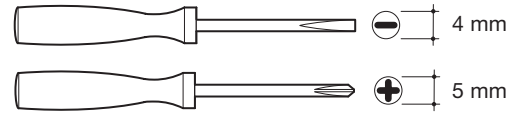
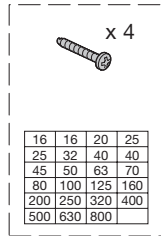
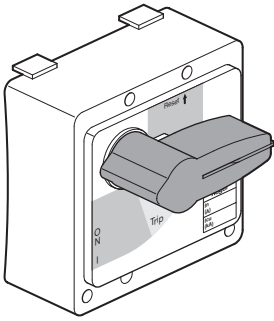

3 - 4 P

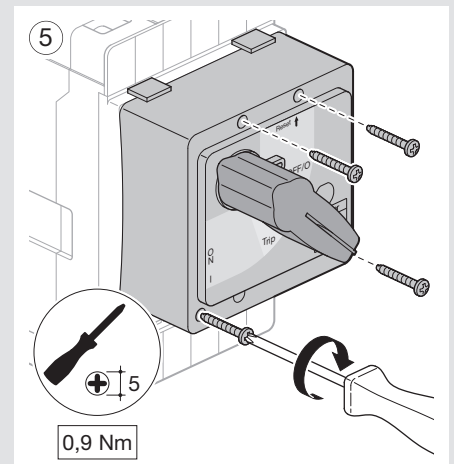
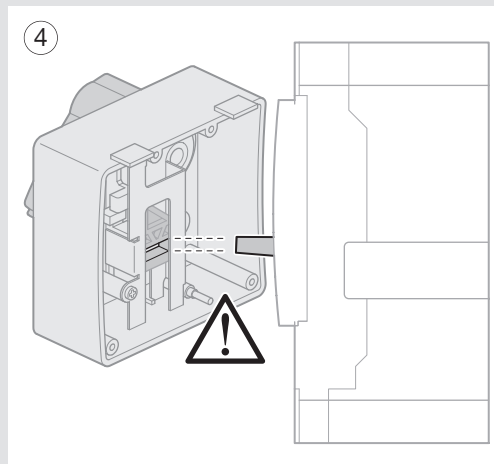
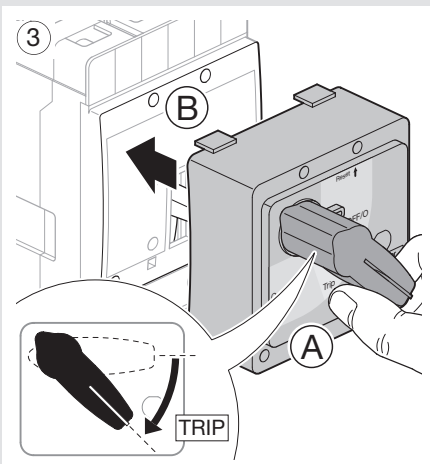
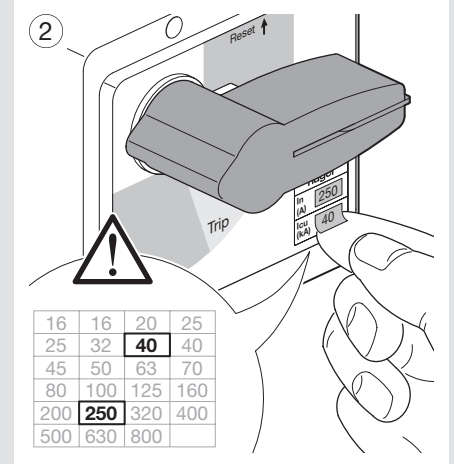
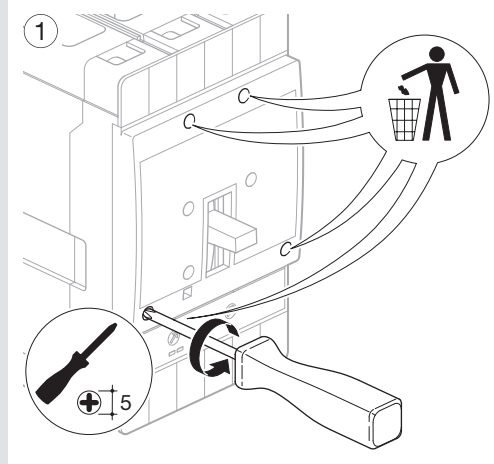
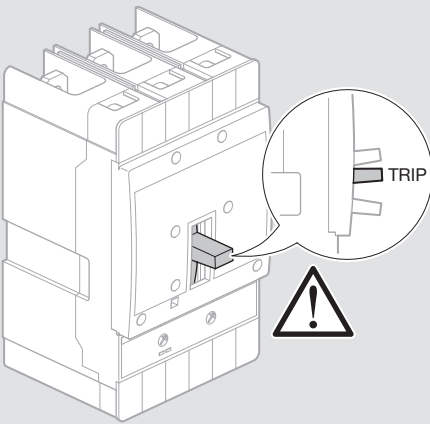

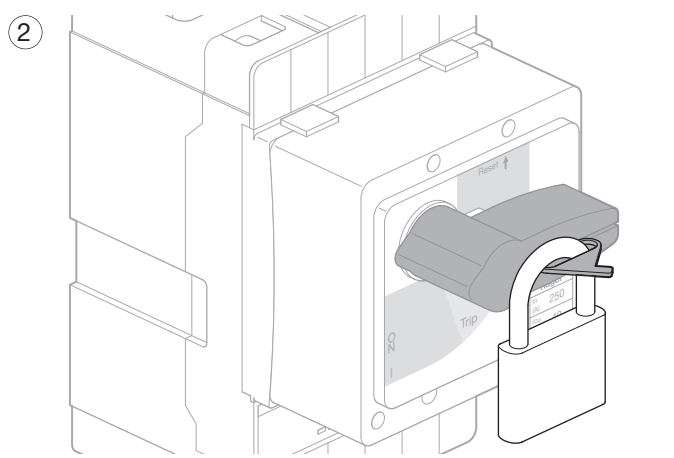
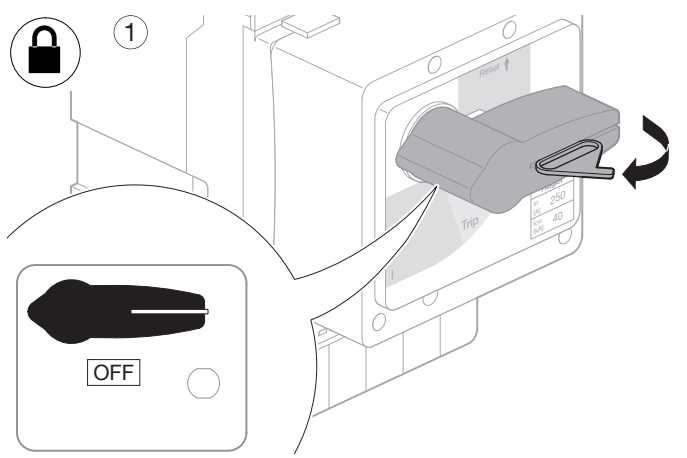
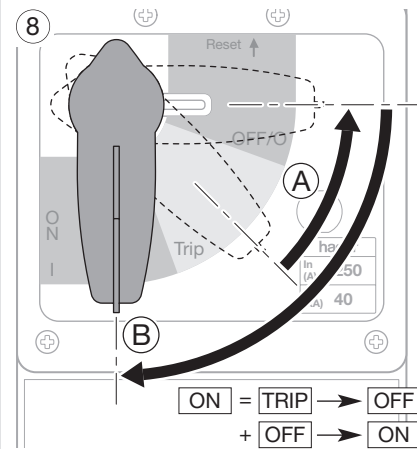
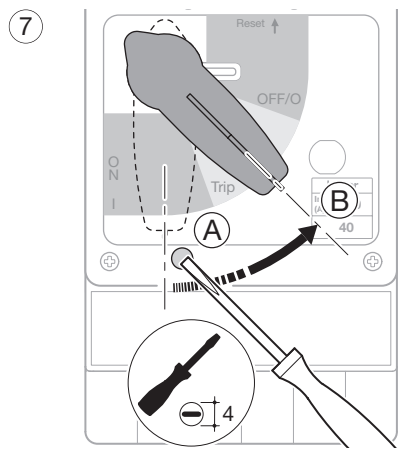
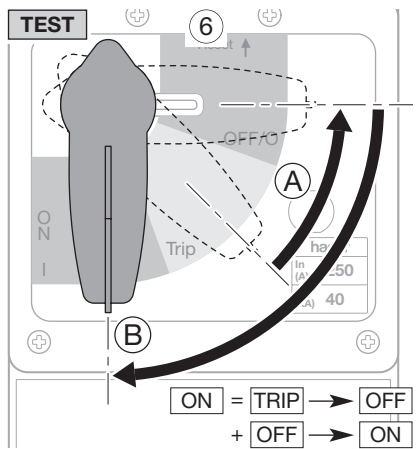

F Garantie

24 mois contre tous vices de matières ou de fabrication, à partir de leur date de production. En cas de défectuosité, le produit doit être remis au grossiste habituel. La garantie ne joue que si la procédure de retour via l'installateur et le grossiste est respectée et si après expertise notre service contrôle qualité ne détecte pas un défaut dû à une mise en œuvre et/ou une utilisation non conforme aux règles de l'art. Les remarques éventuelles expliquant la défectuosité devront accompagner le produit.

GB Warranty

A warranty period of 24 months is offered on hager products, from date of manufacture, relating to any material of manufacturing defect. If any product is found to be defective it must be returned via the installer and supplier (wholesaler). The warranty is withdrawn if:

- after inspection by hager quality control dept the device is found to have been installed in a manner which is contrary to IEE wiring regulations and accepted practice within the industry at the time of installation.
 - the procedure for the return of goods has not been followed.
- Explanation of defect must be included when returning goods.

D Garantie

Es gelten die Allgemeinen Geschäftsbedingungen der Hager Electro GmbH. bzw. die gesetzliche Regelung.

I Garanzia

24 mesi contro tutti i vizi di materiale o di fabbricazione, a partire dalla data di produzione. In caso di difetti, il prodotto deve essere restituito al grossista abituale. La garanzia ha valore solo se viene rispettata la procedura di reso tramite installatore e grossista e se dopo la verifica del nostro servizio controllo qualità non vengono riscontrati difetti dovuti ad una messa in opera e/o ad una utilizzazione non conforme alle regole dell'arte. Le eventuali note esplicative del difetto dovranno accompagnare il prodotto.

E Garantía

24 meses a partir de la fecha de fabricación contra todo defecto de fabricación o de los materiales.

En caso de un aparato defectuoso, el material deberá ser remitido a su almacén habitual. La garantía no será válida si el retorno no se efectúa a través del almacén que ha realizado la venta, si nuestro servicio de control de calidad detecta una mala puesta en funcionamiento o una mala utilización del aparato.

El aparato deberá ser acompañado de un informe explicando la defectuosidad.

NL Garantie

24 maanden op materiaal- of fabricagegebreken, vanaf de fabricage-datum. Bij gebreken moet het product via de leverancier, franco, vrij van kosten, worden geretourneerd. De garantie is alleen van toepassing indien de procedure van retournering in acht is genomen en indien na onderzoek geen gebrek is vastgesteld wegens het verkeerd in werking stellen en/of het niet gebruiken volgens de NEN voorschriften. Wij verzoeken u een schriftelijke opgave van de klacht bij retournering bij te sluiten.

P Garantia

24 meses contra defeitos dos materiais ou de fabrico, a partir da data de produção. No caso de avaria o produto deve ser enviado ao seu distribuidor habitual. A garantia só é válida se forem respeitados todos os nossos procedimentos de devolução, instalador via distribuidor, se os nossos serviços de controlo de qualidade não detectarem más ligações e/ou uma utilização não conforme com as regras de arte. Todas as informações que expliquem o defeito deverão acompanhar o produto.

N Garanti

24 måneders garanti fra fakturadato. Garantien gjelder alle fabrikkasjons- og materialfeil under forutsetning av at det defekte produkt returneres til grossist eller importør med en kort beskrivelse av feilen, samt kopi av pakkeseddel eller faktura. Garantien bortfaller dersom hager's kvalitetskontroll finner at produktet er i brukbar stand, eller at det ikke er montert ifølge gjeldende forskrifter.

GR Εγγύηση

Εγγύηση 24 μηνών προσφέρεται στα προϊόντα της Hager από την ημερομηνία παραγωγής τους, για κάθε ελάττωμα στα υλικά ή την κατασκευή. Εάν κάποιο από τα προϊόντα βρεθεί ελαττωματικό πρέπει να επιστραφεί μέσω του εμπόρου. Η εγγύηση δεν ισχύει εάν: - κατά τον έλεγχο από το τμήμα ποιότητας της Hager βρεθεί ότι η εγκατάσταση έγινε αντίθετα με τους κανονισμούς IEE και την ισχύουσα πρακτική. - δεν έχει ακολουθηθεί η διαδικασία για την επιστροφή του υλικού. Η επιστροφή του υλικού πρέπει να συνοδεύεται με περιγραφή του σφάλματος.