

Modular Circuit Protection

Our range of Modular Circuit Protection offers high quality and practical solutions and options for protecting electrical circuits, people, equipment, and property.

We offer a wide range of circuit protection such as Miniature Circuit Breakers (MCB), Residual Current Breaker with Overcurrent Protection (RCBO), Residual Current Circuit Breaker (RCCB) and Surge Protection Devices (SPD).

A range of accessories are also available including Busbars, Auxiliary Contacts and Relays. three phase RCD Add-On Block (AOB) for MCB, Fuse Carriers and DIN HRC Fuse Carriers.

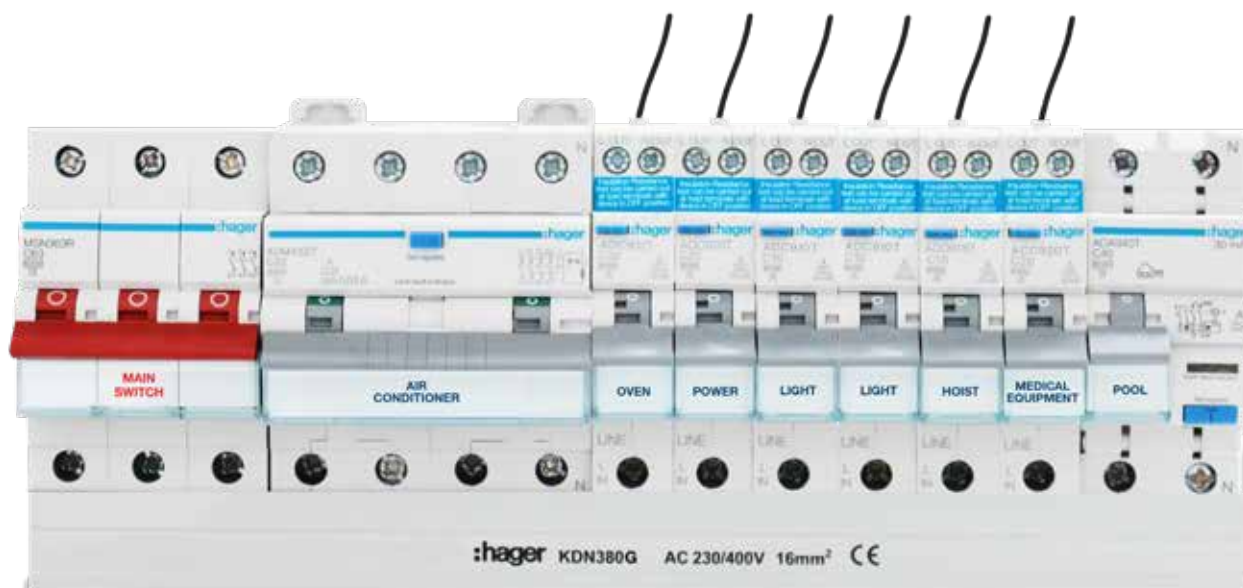

MCBs - 6-63A 6kA 'C' curve	228
MCBs - 6-63A 6kA 'D' curve	229
MCBs - 6-63A 10kA 'C' curve	230
MCBs - 6-63A 10kA 'D' curve	231
MCBs - 80-125A 10kA 'C' curve	232
MCBs - 80-125A 10kA 'D' curve	233
MCB Accessories	234
RCBOs - Residential	238
RCBOs - Commercial	241
RCCBs - Safety Switches	244
RCBO and RCCB Accessories	247
One Module Add-On Blocks (AOB)	248
Insulated Busbars & Connectors	249
Surge Protection Devices (SPD)	252
Fuses & Carriers	257
Technical Information	259

onekonekt Residential installation system

Our onekonekt system offers one of the most versatile and flexible solutions on the market today. The use of busbar is not a new concept - however providing a full range of residential circuit protection, for both single phase and three

phase installations, that can all connect to the same busbar, increasing safety, reducing installation time, improving technical characteristics and aesthetics within one system, definitely is.

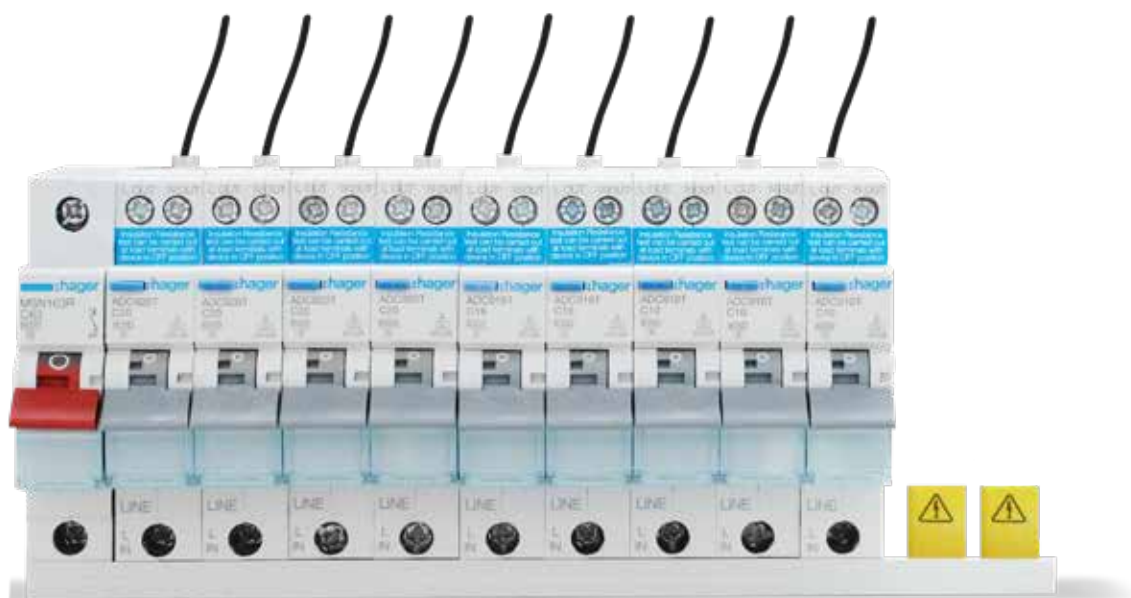



01

Protect your loads with a compact RCBO protection device. Can be used in both 6kA and 10kA applications.

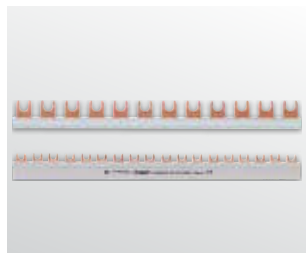

02

The onekonekt system is based on a single phase or three phase forked busbar.



03

Multi-position extended length DIN clip feature, makes removing a product off the DIN rail quick and simple.



04

Provision of two terminals on all devices enable supply from either cables in the cage terminal or busbars in the slot terminal.



05

The neutral busbar slot on two and four module wide RCD and RCBO devices is insulated, allowing one or three phase live busbar to pass through.



06

Busbar is held in position prior to tightening screw terminals with our unique clip system.



07

Protective windows allow for circuit identification to remain in place, including the Hager Semiolog labelling tool.



08

Unused busbar forks or length can remain in-situ for future use. For safety, compliance and rapid future expansion or modification.

Save space in commercial panelboards

Our single module wide RCD Add-On Block (AOB) is designed to convert any Hager three module MCB up to 63A into a four module wide RCBO. This can save up to 40% of space in the commercial and light industrial applications.

For single phase circuits, Hager one module wide 6kA and 10kA commercial RCBOs offer a reliable space saving solution within your panelboards.



Add-On Block characteristics:

- Rated current (I _n):	- fits to any Hager 3 module MCB up to 63A
- Rated voltage (U _n):	- 240V~
- Rated residual operating current (I _{Δn}):	- 30mA, 100mA, 300mA
- Operating characteristic:	- Type A
- Rated frequency:	- 50Hz
- Rated short-circuit capacity (I _{cn}):	- 6kA, 10kA
- Standards compliance:	- AS/NZS 61009.1 - AS/NZS 3000:2018

1 module RCBO characteristics:

- Rated current (I _n):	- 6A to 45A
- Rated voltage (U _n):	- 240V~
- Rated residual operating current (I _{Δn}):	- 10mA, 30mA
- Curve type:	- C
- Operating characteristic:	- Type A
- Rated frequency:	- 50Hz
- Rated short-circuit capacity (I _{cn}):	- 6kA, 10kA
- Standards compliance:	- AS/NZS 61009.1 - IEC 61009.1



01

The Bx163T AOB + three module wide MCB only requires four spare poles. Many other devices can demand up to seven spare poles.



02

All of our three module wide MCBs have a detachable cover built into the casing to accommodate accessories.



03

The Bx163T AOB operates between active and neutral OR between actives to protect unbalanced or balanced loads.



04

The commercial single module wide RCBO has an earth lead to ensure earth leakage detection, in case of accidental loss of neutral in the installation.



05

The commercial MCBs and RCBOs come in either 6kA or 10kA breaking capacity to ensure adequate discrimination.



06

Available in Type A 10mA and 30mA for a range of protection scenarios.

Modular Circuit Protection

MCBs 6-63A 6kA 'C' curve

Description

For general distribution loads, our MSNxxx Miniature Circuit Breaker (MCB) range short circuit and overcurrent protection of installations by isolating the circuit.

The red toggle on the MSNx63R gives a visual differentiation when used as a main switch device.

Technical data

- Tripping curve - 'C' magnetic setting between 5 and 10 I_n
- Breaking capacity: 6,000A
- Voltage rating: 230V /400V (Not for use on DC)
- Current rating: 6 to 63A
- Bi-connect terminals enable supply from either cables in the cage or busbars in the slot.

Connection capacity

- 25mm² rigid
- 16mm² flexible

Standards

- AS/NZS 60898-1
- AS/NZS 3000

Technical information [Page 260](#)

Accessories for MSNxxx

- LZ060, MZN175, MZ201, MZ202, MZ203, MZ204, MZ206, MZN120, MZN121, Bx163T



MSN163 MSN163R

Single pole



Current Rating (A)	Module(s)	Width (mm)	Box Qty	Cat ref.
6	1 mod	17.5	12	MSN106
10	1 mod	17.5	12	MSN110
13	1 mod	17.5	12	MSN113
16	1 mod	17.5	12	MSN116
20	1 mod	17.5	12	MSN120
25	1 mod	17.5	12	MSN125
32	1 mod	17.5	12	MSN132
40	1 mod	17.5	12	MSN140
50	1 mod	17.5	12	MSN150
63	1 mod	17.5	12	MSN163
63	1 mod	17.5	12	MSN163R

Modular Protection devices



MSN220 MSN263R

Double pole



Current Rating (A)	Module(s)	Width (mm)	Box Qty	Cat ref.
6	2 mod	35	6	MSN206
10	2 mod	35	6	MSN210
16	2 mod	35	6	MSN216
20	2 mod	35	6	MSN220
25	2 mod	35	6	MSN225
32	2 mod	35	6	MSN232
40	2 mod	35	6	MSN240
50	2 mod	35	6	MSN250
63	2 mod	35	6	MSN263
63	2 mod	35	6	MSN263R



MSN320

Triple pole

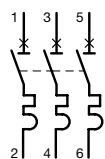

Current Rating (A)	Module(s)	Width (mm)	Box Qty	Cat ref.
6	3 mod	52.5	4	MSN306
10	3 mod	52.5	4	MSN310
16	3 mod	52.5	4	MSN316
20	3 mod	52.5	4	MSN320
25	3 mod	52.5	4	MSN325
32	3 mod	52.5	4	MSN332
40	3 mod	52.5	4	MSN340
50	3 mod	52.5	4	MSN350
63	3 mod	52.5	4	MSN363
63	3 mod	52.5	4	MSN363R



MSN363R

Description

Our range of MDNxxx MCBs provides short circuit and overcurrent protection of installations by isolating the circuit.

The red toggle on the MDNx63R gives a differentiation when used as a service protection device.

Technical data

- Tripping curve - 'D' magnetic setting between 10 and 20In
- Breaking capacity: 6,000A
- Voltage rating: 230V /400V (Not for use on DC)
- Current rating: 6 to 63A
- Bi-connect terminals enable supply from either cables in the cage or busbars in the slot.

Connection capacity

- 25mm² rigid
- 16mm² flexible

Accessories for MDNxxx

- LZ060, MZN175, MZ201, MZ202, MZ203, MZ204, MZ206, MZN120, MZN121, Bx163T

Standards

- AS/NZS 60898-1
- AS/NZS 3000

Technical information [Page 262](#)



Single pole



Current Rating (A)	Module(s)	Width (mm)	Box Qty	Cat ref.
6	1 mod	17.5	12	★ MDN106P
10	1 mod	17.5	12	★ MDN110P
16	1 mod	17.5	12	★ MDN116P
20	1 mod	17.5	12	★ MDN120P
25	1 mod	17.5	12	★ MDN125P
32	1 mod	17.5	12	★ MDN132P
40	1 mod	17.5	12	★ MDN140P
50	1 mod	17.5	12	★ MDN150P
63	1 mod	17.5	12	★ MDN163P
63	1 mod	17.5	12	★ MDN163R



MDN116P

MDN163R

Double pole



Current Rating (A)	Module(s)	Width (mm)	Box Qty	Cat ref.
6	2 mod	35	6	★ MDN206P
10	2 mod	35	6	★ MDN210P
16	2 mod	35	6	★ MDN216P
20	2 mod	35	6	★ MDN220P
25	2 mod	35	6	★ MDN225P
32	2 mod	35	6	★ MDN232P
40	2 mod	35	6	★ MDN240P
50	2 mod	35	6	★ MDN250P
63	2 mod	35	6	★ MDN263P
63	2 mod	35	6	★ MDN263R



MDN232P

MDN263R

Triple pole

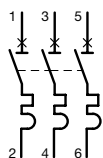

Current Rating (A)	Module(s)	Width (mm)	Box Qty	Cat ref.
6	3 mod	52.5	4	★ MDN306P
10	3 mod	52.5	4	★ MDN310P
16	3 mod	52.5	4	★ MDN316P
20	3 mod	52.5	4	★ MDN320P
25	3 mod	52.5	4	★ MDN325P
32	3 mod	52.5	4	★ MDN332P
40	3 mod	52.5	4	★ MDN340P
50	3 mod	52.5	4	★ MDN350P
63	3 mod	52.5	4	★ MDN363P
63	3 mod	52.5	4	★ MDN363R



MDN316P



MDN363R

Modular Circuit Protection

MCBs 6-63A 10kA 'C' curve

Description

For general distribution loads, our NTxxxx Miniature Circuit Breaker (MCB) range provides short circuit and overcurrent protection of installations by isolating the circuit.

Technical data

- Tripping curve - 'C' magnetic setting between 5 and 10I_n
- Breaking capacity: 10kA
- Voltage rating: 230V /400V (Not for use on DC)
- Current rating: 2 to 63A
- Load and line circuits may be connected top or bottom.

Connection capacity

- 35mm² rigid
- 26mm² flexible

Standards

- AS/NZS 60898-1
- AS/NZS 3000

Technical information [Page 264](#)

Accessories

- LZ060, MZN175, MZ201, MZ202, MZ203, MZ204, MZ206, MZN120, MZN121, Bx163T



NT110C

Single pole



Current Rating (A)	Module(s)	Width (mm)	Pack Qty	Cat ref.
2	1 mod	17.5	12	NT102C
4	1 mod	17.5	12	NT104C
6	1 mod	17.5	12	NT106C
10	1 mod	17.5	12	NT110C
16	1 mod	17.5	12	NT116C
20	1 mod	17.5	12	NT120C
25	1 mod	17.5	12	NT125C
32	1 mod	17.5	12	NT132C
40	1 mod	17.5	12	NT140C
50	1 mod	17.5	12	NT150C
63	1 mod	17.5	12	NT163C



NT216C

Double pole



Current Rating (A)	Module(s)	Width (mm)	Pack Qty	Cat ref.
2	2 mod	35	6	NT202C
4	2 mod	35	6	NT204C
6	2 mod	35	6	NT206C
10	2 mod	35	6	NT210C
16	2 mod	35	6	NT216C
20	2 mod	35	6	NT220C
25	2 mod	35	6	NT225C
32	2 mod	35	6	NT232C
40	2 mod	35	6	NT240C
50	2 mod	35	6	NT250C
63	2 mod	35	6	NT263C



NT304C

Triple pole

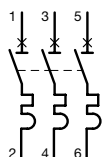

Current Rating (A)	Module(s)	Width (mm)	Pack Qty	Cat ref.
2	3 mod	52.5	6	NT302C
4	3 mod	52.5	6	NT304C
6	3 mod	52.5	6	NT306C
10	3 mod	52.5	6	NT310C
16	3 mod	52.5	6	NT316C
20	3 mod	52.5	6	NT320C
25	3 mod	52.5	6	NT325C
32	3 mod	52.5	6	NT332C
40	3 mod	52.5	6	NT340C
50	3 mod	52.5	6	NT350C
63	3 mod	52.5	6	NT363C

Description

For general distribution loads, our NDNxxxx Miniature Circuit Breaker (MCB) range provides short circuit and overcurrent protection of installations by isolating the circuit.

Technical data

- Tripping curve - 'D' magnetic setting between 10 and 20In
- Breaking capacity: 10kA (AS/NZS 60898-1) 15kA (IEC 60947-2)
- Voltage rating: 230V /400V (Not for use on DC)
- Current rating: 6 to 63A

Connection capacity

- 35mm² rigid
- 26mm² flexible

Accessories

- LZ060, MZN175, MZ201, MZ202, MZ203, MZ204, MZ206, MZN120, MZN121, Bx163T

Standards

- AS/NZS IEC 60947-2 compliant

Technical information [Page 267](#)



Single pole



Current Rating (A)	Module(s)	Width (mm)	Pack Qty	Cat ref.
6	1 mod	17.5	12	NDN106A
10	1 mod	17.5	12	NDN110A
16	1 mod	17.5	12	NDN116A
20	1 mod	17.5	12	NDN120A
25	1 mod	17.5	12	NDN125A
32	1 mod	17.5	12	NDN132A
40	1 mod	17.5	12	NDN140A
50	1 mod	17.5	12	NDN150A
63	1 mod	17.5	12	NDN163A



NDN116A

Double pole



Current Rating (A)	Module(s)	Width (mm)	Pack Qty	Cat ref.
6	2 mod	35	6	NDN206A
10	2 mod	35	6	NDN210A
16	2 mod	35	6	NDN216A
20	2 mod	35	6	NDN220A
25	2 mod	35	6	NDN225A
32	2 mod	35	6	NDN232A
40	2 mod	35	6	NDN240A
50	2 mod	35	6	NDN250A
63	2 mod	35	6	NDN263A



NDN232A

Modular Protection devices

Triple pole

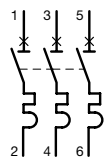

Current Rating (A)	Module(s)	Width (mm)	Pack Qty	Cat ref.
6	3 mod	52.5	4	NDN306A
10	3 mod	52.5	4	NDN310A
16	3 mod	52.5	4	NDN316A
20	3 mod	52.5	4	NDN320A
25	3 mod	52.5	4	NDN325A
32	3 mod	52.5	4	NDN332A
40	3 mod	52.5	4	NDN340A
50	3 mod	52.5	4	NDN350A
63	3 mod	52.5	4	NDN363A



NDN316A

Four pole

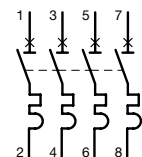

Current Rating (A)	Module(s)	Width (mm)	Pack Qty	Cat ref.
6	4 mod	70	3	NDN406A
10	4 mod	70	3	NDN410A
16	4 mod	70	3	NDN416A
20	4 mod	70	3	NDN420A
25	4 mod	70	3	NDN425A
32	4 mod	70	3	NDN432A
40	4 mod	70	3	NDN440A
50	4 mod	70	3	NDN450A
63	4 mod	70	3	NDN463A



NDN432A

Modular Circuit Protection

MCBs 80-125A 10kA 'C' curve

Description

For general distribution loads, our HMFxxx Miniature Circuit Breaker (MCB) range provides short circuit and overcurrent protection of installations by isolating the circuit.

Technical data

- Tripping curve - 'C' magnetic setting between 5 and 10In
- Breaking capacity: 10kA
- Voltage rating: 230V /400V (Not for use on DC)
- Current rating: 80 to 125A

Connection capacity

- 70mm² rigid
- 35mm² flexible

Standards

- Compliant to AS/NZS 60898-1 and AS/NZS IEC 60947-2

Technical information [Page 268](#)

Accessories

- LZ060, MZN175, MZ201, MZ202, MZ203, MZ204, MZ206, CZ001



HMF199T

Single pole



In / A	Module(s)	Width (mm)	Cat ref.
80	1.5 mod	26.25	HMF180T
100	1.5 mod	26.25	HMF190T
125	1.5 mod	26.25	HMF199T



HMF299T

Double pole



In / A	Module(s)	Width (mm)	Cat ref.
80	3 mod	52.5	HMF280T
100	3 mod	52.5	HMF290T
125	3 mod	52.5	HMF299T



HMF399T

Triple pole

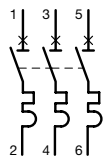

In / A	Module(s)	Width (mm)	Cat ref.
80	4.5 mod	78.75	HMF380T
100	4.5 mod	78.75	HMF390T
125	4.5 mod	78.75	HMF399T

Description

For general distribution loads, our HMCxxxx and HMDxxxx Miniature Circuit Breaker (MCB) range provides short circuit and overcurrent protection of installations by isolating the circuit.

Technical data

- Tripping curve - 'C' magnetic setting between 5 and 10In
- Tripping curve - 'D' magnetic setting between 10 and 20In
- Breaking capacity: 15kA
- Voltage rating: 230V /400V (Not for use on DC)
- Current rating: 80 to 125A

Connection capacity

- 70mm² rigid
- 35mm² flexible

Accessories

- LZ060, MZN175, MZ201, MZ202, MZ203, MZ204, MZ206,

Standards

- Compliant to AS/NZS 60898-1 and AS/NZS IEC 60947-2

Technical information [Page 268](#)



Single pole



In / A	Module(s)	Width (mm)	Cat ref. 'C' curve	Cat ref. 'D' curve
80	1.5 mod	26.25	HMC180T	HMD180T
100	1.5 mod	26.25	HMC190T	HMD190T
125	1.5 mod	26.25	HMC199T	HMD199T



HMC199T

Double pole



In / A	Module(s)	Width (mm)	Cat ref. 'C' curve	Cat ref. 'D' curve
80	3 mod	52.5	HMC280T	HMD280T
100	3 mod	52.5	HMC290T	HMD290T
125	3 mod	52.5	HMC299T	HMD299T



HMD299T

Triple pole

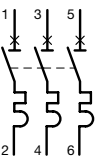

In / A	Module(s)	Width (mm)	Cat ref. 'C' curve	Cat ref. 'D' curve
80	4.5 mod	78.75	HMC380T	HMD380T
100	4.5 mod	78.75	HMC390T	HMD390T
125	4.5 mod	78.75	HMC399T	HMD399T



HMC399T

Four pole

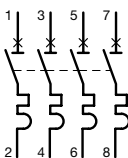

In / A	Module(s)	Width (mm)	Cat ref. 'C' curve	Cat ref. 'D' curve
80	4.5 mod	78.75	HMC480T	HMD480T
100	4.5 mod	78.75	HMC490T	HMD490T
125	4.5 mod	78.75	HMC499T	HMD499T



HMD499T

Accessories to suit HMF, HMC and HMD

Description	Characteristics	Cat ref.
Terminal covers	Sealable	MZN130
Phase barrier	1 set of 3 phase barriers	MZN131



Description

Auxiliaries are common to all MCBs. These auxiliaries are fitted to the left hand side of the devices.

Connection

- 10mm² rigid
- 6mm² flexible

Compatibility chart and

Technical information [Page 278](#)



MZ202



MZ203



MZN175



LZ060





MZN120



MZN121

Accessories

Description	Characteristics	Module(s)	Width (mm)	Cat ref.
Combination auxiliary & alarm contacts 6A-240V~	2 x 1NO + 1NC Allows remote indication of main contact status and indicates a fault condition.	1	17.5	CZ001
Auxiliary contacts 6A - 230V~ 	1NO + 1NC allows remote indication of main contact status	0.5	8.75	MZ201
Alarm contacts 6A - 230V~. 	1NO + 1NC indicates a fault over current on overload or short circuit (e.g. MCB tripped)	0.5	8.75	MZ202
Shunt trip relay Allows remote tripping of (combined) RCD when a voltage is applied. 	230V - 415V AC	1	17.5	MZ203
	110V to 130V DC	1	17.5	MZ204
Undervoltage release 230V AC	If supply falls to 35 to 70% of nominal voltage the MCB will trip Coil consumption: 3.5 VA	1	17.5	MZ206
Locking device	To lock the MCB handle in on/off position	1	17.5	MZN175
Heat dissipation inserts	Avoids overheating for DIN rail modules when several devices mounted side by side are carrying high continuous loads	0.5	8.75	LZ060
Terminal cover & screw shield for MCBs				MZN120
Phase barriers for MDNxxx + NDNxxx MCBs	1 set of 3			MZN121

Space saving 4P RCBO



From complex to

Compact

At only four modules wide and compatible with Hager onekonekt busbar and Modular Circuit Protection, three phase RCBO protection has never been so space friendly. With the choice of either 6kA or 10kA, from 6A to 40A and in either 30mA or 100mA, our new four pole RCBO provides combined RCD and MCB protection in a single robust DIN rail mounted design.

A compact solution for DIN rail enclosures

Our residential range of single module and four module Residual Current Circuit Breakers with Overcurrent Protection (RCBO) can be integrated with other Hager Modular Circuit Protection Devices.

Our ADC9xxT RCBO or 'onekombo' is only one module wide, making it ideal for retrofit installations where space can be limited. onekombo RCBO devices can be used in DIN rail enclosures and invicta panelboards.



One module RCBO onekombo characteristics:

- Rated current (I _n):	- 6A to 32A
- Rated voltage (U _n):	- 230V~
- Rated residual operating current (I _{Δn}):	- 30mA
- Curve type:	- C
- Operating characteristic:	- Type A
- Rated frequency:	- 50Hz
- Rated short-circuit capacity (I _{cn}):	- 6kA
- Standards compliance:	- AS/NZS 61009

Four module RCBO characteristics:

- Rated current (I _n):	- 6A to 40A
- Rated voltage (U _n):	- 400V~
- Rated residual operating current (I _{Δn}):	- 30mA, 100mA
- Curve type:	- C
- Operating characteristic:	- Type A
- Rated frequency:	- 50Hz
- Rated short-circuit capacity (I _{cn}):	- 6kA, 10kA
- Standards compliance:	- AS/NZS 61009



01

Type A RCBOs increase the accuracy in identifying DC faults in electrical devices.



02

Devices are compatible with the one-konekt busbar system.



03

Long multi position DIN clips allow for easy removal of a single product on the DIN rail busbar without disconnecting other devices or wiring.



04

Four module RCBOs have the earth fault trip indication displayed in a separate window to assist in fault finding.



05

A space saving solution to protect 4 pole loads with a four module wide RCBO device.

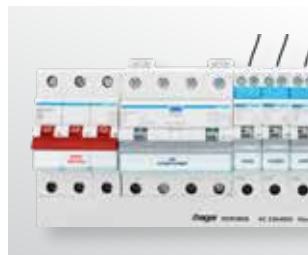

06

The neutral in the four module RCBOs can be wired to the neutral link or connected through our KB181x busbar to comply with AS/NZS 3000.



07

Mounted to the left of the four module RCBO, auxiliaries remotely indicate the position or trip condition of the device.



08

The four module RCBO is suitable for balanced or unbalanced loads across phases when 400V AC is between phases.

Description

Our Axx9xxT RCBO or 'onekombo' are only one module wide, making them ideal for retrofit in installations where space is limited.

Available as 'C' or 'D' curve in various current ratings from 6A - 40A. Supplied with a 1 metre long neutral-in fly lead. Available in 10 and 30mA.

Onekombo RCBO devices can be used in DIN rail enclosures and the invicta panelboard range.

Features

- Type A devices
- Switched neutral
- Fault indication window
- Bi-connect terminals enable supply from either cables in the cage or busbars in the slot.
- Bi-directional
- Facility insulation resistance test

1 mod connection capacity

- 10mm² flexible
- 16mm² rigid

Standards

- Compliant to IEC 61009.1 and AS/NZS 61009.1
- ACC9xxT is Type I to comply with AS/NZS 3190 requirements, suitable for patient areas.

Technical information:

[Page 270](#)



ADC920T

RCBO 1P+N 6kA C curve

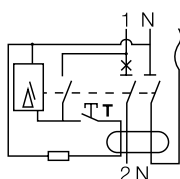

Current rating (A)	Residual current I _{dn}	Module(s)	Width (mm)		Cat ref.
6A	30mA	1 mod	17.5	✗ ADC306T	→ ★ ADC906T
10A	30mA	1 mod	17.5	✗ ADC310T	→ ★ ADC910T
13A	30mA	1 mod	17.5	✗ ADC313T	→ ★ ADC913T
16A	30mA	1 mod	17.5	✗ ADC316T	→ ★ ADC916T
20A	30mA	1 mod	17.5	✗ ADC320T	→ ★ ADC920T
25A	30mA	1 mod	17.5	✗ ADC325T	→ ★ ADC925T
32A	30mA	1 mod	17.5	✗ ADC332T	→ ★ ADC932T
6A	10mA	1 mod	17.5		★ ACC906T
10A	10mA	1 mod	17.5		★ ACC910T
13A	10mA	1 mod	17.5		★ ACC913T
16A	10mA	1 mod	17.5		★ ACC916T
20A	10mA	1 mod	17.5		★ ACC920T
25A	10mA	1 mod	17.5		★ ACC925T
32A	10mA	1 mod	17.5		★ ACC932T



ACC925T

Modular Protection devices



ADD920T

RCBO 1P+N 6kA D curve

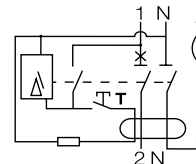

Current rating (A)	Residual current I _{dn}	Module(s)	Width (mm)		Cat ref.
6A	30mA	1 mod	17.5		★ ADD906T
10A	30mA	1 mod	17.5		★ ADD910T
13A	30mA	1 mod	17.5		★ ADD913T
16A	30mA	1 mod	17.5		★ ADD916T
20A	30mA	1 mod	17.5		★ ADD920T
25A	30mA	1 mod	17.5		★ ADD925T

Description

Our AxA9xxT RCBO are two module wide, making them ideal for retrofit in installations where space is limited.

Available as 'C' curve in various current ratings from 6A - 40A. Available in 30 and 100mA.

Can be used in DIN rail enclosures and the invicta panelboard range.

Features

- Type A devices
- Switched neutral
- Fault indication window
- Bi-connect terminals enable supply from either cables in the cage or busbars in the slot.
- Load and line circuits may be connected top or bottom.
- Facility insulation resistance test

2 mod connection capacity

- 16mm² flexible
- 25mm² rigid

Standards

- Compliant to IEC 61009.1 and AS/NZS 61009.1

Technical information:
[Page 271](#)



RCBO 1P+N 6kA
C curve

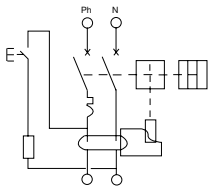

Current rating (A)	Residual current Idn	Module(s)	Width (mm)	Cat ref.
6A	30mA	2 mod	35	ADA906T
10A	30mA	2 mod	35	ADA910T
13A	30mA	2 mod	35	ADA913T
16A	30mA	2 mod	35	ADA916T
20A	30mA	2 mod	35	ADA920T
25A	30mA	2 mod	35	ADA925T
32A	30mA	2 mod	35	ADA932T
40A	30mA	2 mod	35	ADA940T
6A	100mA	2 mod	35	AEA906T
10A	100mA	2 mod	35	AEA910T
13A	100mA	2 mod	35	AEA913T
16A	100mA	2 mod	35	AEA916T
20A	100mA	2 mod	35	AEA920T
25A	100mA	2 mod	35	AEA925T
32A	100mA	2 mod	35	AEA932T
40A	100mA	2 mod	35	AEA940T



ADA910T



AEA910T

Modular Protection devices

Description

Our AxM4xxT are 4 pole RCBO devices which provide a combination of overcurrent and earth leakage protection.

Available as 'C' curve in various current ratings from 6A to 40A. Available in 30mA and 100mA.

4P RCBO devices can only be used for DIN rail enclosures. Suitable for balanced and unbalanced loads.

Features

- Type A devices
- Earth fault indication window
- Trip free mechanisms
- Load and line circuits may be connected top or bottom.
- Bi-connect terminals enable supply from either cables in the cage or busbars in the slot.
- Switched neutral

Accessories

- MZ201, MZ202, MZ203, MZ204, MZ206

Standards

- Compliant to IEC 61009.1 and AS/NZS 61009.1

Technical information:

[Page 272](#)

4 mod connection capacity

- 16mm² flexible
- 25mm² rigid



ADM413T



AEM420T

RCBO 4P 6kA C curve

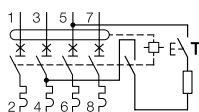

Current rating (A)	Residual current I _{dn}	Module(s)	Width (mm)	Cat ref.
6A	30mA	4 mod	70	ADM406T
10A	30mA	4 mod	70	ADM410T
13A	30mA	4 mod	70	ADM413T
16A	30mA	4 mod	70	ADM416T
20A	30mA	4 mod	70	ADM420T
25A	30mA	4 mod	70	ADM425T
32A	30mA	4 mod	70	ADM432T
40A	30mA	4 mod	70	ADM440T
6A	100mA	4 mod	70	AEM406T
10A	100mA	4 mod	70	AEM410T
13A	100mA	4 mod	70	AEM413T
16A	100mA	4 mod	70	AEM416T
20A	100mA	4 mod	70	AEM420T
25A	100mA	4 mod	70	AEM425T
32A	100mA	4 mod	70	AEM432T
40A	100mA	4 mod	70	AEM440T

Description

Our AxA1xxT and Ax1xxB are 1 pole RCBO devices which provide a combination of overcurrent and earth leakage protection.

Available as 'C' curve in various current ratings from 6A to 45A. Available in 10mA and 30mA.

The single pole RCBO devices can be used in DIN rail enclosures and the perform panelboard range.

Features

- Type A devices

Connection capacity

- 16mm² flexible
- 25mm² rigid

Accessories

- Toggle locking device - MZN175

Accessories -

- MZ201, MZ202, MZ203, MZ204, MZ206

Standards

- Compliant to IEC 61009.1 and AS/NZS 61009.1
- ACA5xxT is Type 1 according to AS/NZS 3190
- ACA1xxT and AC1xxB are general type, not for patient areas according to AS/NZS 3190

Technical information:

[Page 273](#)



RCBO 1P 6kA Type A C curve

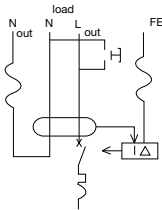

Current rating (A)	Residual current I _{dn}	Module(s)	Width (mm)	Cat. ref.
6A	10mA	1 mod	17.5	ACA106T
10A	10mA	1 mod	17.5	ACA110T
16A	10mA	1 mod	17.5	ACA116T
20A	10mA	1 mod	17.5	ACA120T
25A	10mA	1 mod	17.5	ACA125T
32A	10mA	1 mod	17.5	ACA132T
6A	30mA	1 mod	17.5	ADA106T
10A	30mA	1 mod	17.5	ADA110T
16A	30mA	1 mod	17.5	ADA116T
20A	30mA	1 mod	17.5	ADA120T
25A	30mA	1 mod	17.5	ADA125T
32A	30mA	1 mod	17.5	ADA132T
40A	30mA	1 mod	17.5	ADA140T
45A	30mA	1 mod	17.5	ADA145T



ACA110T



ADA140T

Modular Protection devices

RCBO 1P 10kA Type A C curve

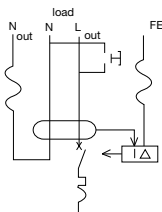

Current rating (A)	Residual current I _{dn}	Module(s)	Width (mm)	Cat. ref.
6A	10mA	1 mod	17.5	AC106B
10A	10mA	1 mod	17.5	AC110B
16A	10mA	1 mod	17.5	AC116B
20A	10mA	1 mod	17.5	AC120B
25A	10mA	1 mod	17.5	AC125B
32A	10mA	1 mod	17.5	AC132B
6A	30mA	1 mod	17.5	AD106B
10A	30mA	1 mod	17.5	AD110B
16A	30mA	1 mod	17.5	AD116B
20A	30mA	1 mod	17.5	AD120B
25A	30mA	1 mod	17.5	AD125B
32A	30mA	1 mod	17.5	AD132B



AC106B



AD120B

Description

Our AxA5xxT are 2 pole RCBO devices which provide a combination of overcurrent and earth leakage protection.

Available as 'C' curve in various current ratings from 6A to 45A. Available in 10mA and 30mA.

Features

- Type A devices
- Switched Neutral
- Fault indication window
- Bi-connect terminals enable supply from either cables in the cage or busbars in the slot.
- Load and line circuits may be connected top or bottom.

Connection capacity

- 16mm² flexible
- 25mm² rigid

Accessories

- Toggle locking device - MZN175

Accessories -

- MZ201, MZ202, MZ203, MZ204, MZ206

Standards

- Compliant to IEC 61009.1 and AS/NZS 61009.1
- Earth fault indication window (except for 1mod RCBOs)
- ACA5xxT is Type 1 according to AS/NZS 3190

Technical information:

[Page 274](#)



ACA566T



ADA566T

RCBO 1P+N 10kA Type A C curve

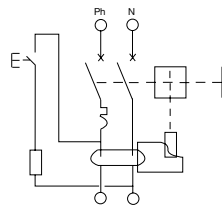

Current rating (A)	Residual current I _{dn}	Module(s)	Width (mm)	Cat ref.
10A	10mA	2 mod	35	ACA560T
13A	10mA	2 mod	35	ACA563T
16A	10mA	2 mod	35	ACA566T
6A	30mA	2 mod	35	ADA556T
10A	30mA	2 mod	35	ADA560T
13A	30mA	2 mod	35	ADA563T
16A	30mA	2 mod	35	ADA566T
20A	30mA	2 mod	35	ADA570T
25A	30mA	2 mod	35	ADA575T
32A	30mA	2 mod	35	ADA582T

Description

Our AxX4xT are 4 pole RCBO devices which provide a combination of overcurrent and earth leakage protection.

Available as 'C' curve in various current ratings from 6A to 40A. Available in 30mA and 100mA and rated at 10kA

The four pole RCBO devices can only be used in DIN rail enclosures. Suitable for balanced and unbalanced loads.

Features

- Type A devices
- Switched neutral
- Fault indication window
- Bi-connect terminals enable supply from either cables in the cage or busbars in the slot.
- Load and line circuits may be connected top or bottom.
- Trip free mechanisms

Connection capacity

- 16mm² flexible
- 25mm² rigid

Accessories 4 mod devices only

- MZ201, MZ202, MZ203, MZ204, MZ206, MZN175

Standards

- Compliant to IEC 61009.1 and AS/NZS 61009.1

Technical information:

[Page 275](#)



RCBO 4P 10kA Type A C curve

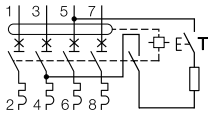

Current rating (A)	Residual current I _{dn}	Module(s)	Width (mm)	Cat. ref.
6A	30mA	4 mod	70	ADX406T
10A	30mA	4 mod	70	ADX410T
13A	30mA	4 mod	70	ADX413T
16A	30mA	4 mod	70	ADX416T
20A	30mA	4 mod	70	ADX420T
25A	30mA	4 mod	70	ADX425T
32A	30mA	4 mod	70	ADX432T
40A	30mA	4 mod	70	ADX440T
6A	100mA	4 mod	70	AEX406T
10A	100mA	4 mod	70	AEX410T
13A	100mA	4 mod	70	AEX413T
16A	100mA	4 mod	70	AEX416T
20A	100mA	4 mod	70	AEX420T
25A	100mA	4 mod	70	AEX425T
32A	100mA	4 mod	70	AEX432T
40A	100mA	4 mod	70	AEX440T



ADX413T



AEX406T

Modular Protection devices

Description

Residual Current Circuit Breaker (RCCB) or 'Safety Switches' are designed to open a protected circuit automatically when the circuit leaks current to earth, greater or equal to the devices rated tripping current.

For use in residential, commercial or industrial installations.

Type A

Type A RCCB is used where the earth fault waveform is sinusoidal AC and/or pulsating DC up to 6mA (computer loads, etc).

Features

- Positive contact indication windows
- Earth fault indication window
- Load and line circuits may be connected top or bottom
- Bi-connect terminals enable supply from either cables in the cage or busbars in the slot.

Connection capacity

- 25mm² - Rigid (50mm² for 80A,100A)
- 16mm² - Flexible (35mm² for 80A, 100A)

Accessories

- MZ201, MZ202, MZ203, MZ204, MZ206, MZN175, LZ060
- CZ001 for CDA2xxT and CDA4xxT
- MZN121 for others

Standards

- All types conform with AS/NZS 61008.1
- Type F compliant to IEC62493

Technical information: [Page 276](#)



CDA240T



CEA563T

RCCB 1P+N Type A

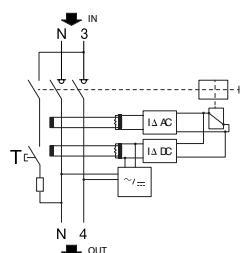

Current rating (A)	Residual current I _{dn}	Module(s)	Width (mm)	Cat ref.
25A	30mA	2 mod	35	CDA225T
40A	30mA	2 mod	35	CDA240T
63A	30mA	2 mod	35	CDA263T
80A	30mA	2 mod	35	CDA580T
100A	30mA	2 mod	35	CDA584T
<hr/>				
25A	100mA	2 mod	35	CEA525T
40A	100mA	2 mod	35	CEA540T
63A	100mA	2 mod	35	CEA563T
80A	100mA	2 mod	35	CEA580T
100A	100mA	2 mod	35	CEA584T

Modular Protection devices



CDA440T



CEA663T

RCCB 3P+N Type A

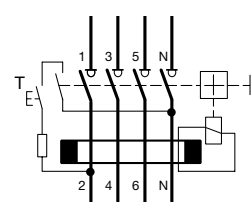

Current rating (A)	Residual current I _{dn}	Module(s)	Width (mm)	Cat ref.
25A	30mA	4 mod	70	CDA425T
40A	30mA	4 mod	70	CDA440T
63A	30mA	4 mod	70	CDA463T
80A	30mA	4 mod	70	CDA680T
100A	30mA	4 mod	70	CDA684T
<hr/>				
25A	100mA	4 mod	70	CEA625T
40A	100mA	4 mod	70	CEA640T
63A	100mA	4 mod	70	CEA663T
80A	100mA	4 mod	70	CEA680T
100A	100mA	4 mod	70	CEA684T

Description

Residual Current Circuit Breaker (RCCB) or 'Safety Switches' are designed to open a protected circuit automatically when the circuit leaks current to earth, greater or equal to the devices rated tripping current.

For use in residential, commercial or industrial installations.

Type F

Type F RCCB can detect and respond similarly as Type A and considers a maximum fault current of 30mA. It also detects mixed frequency residual currents (such as some air conditioning controllers using variable frequency from 10Hz to 1000Hz speed drives, some Class I power tools, etc).

Features

- Positive contact indication windows
- Earth fault indication window
- Load and line circuits may be connected top or bottom
- Bi-connect terminals enable supply from either cables in the cage or busbars in the slot.

Connection capacity

- 25mm² - Rigid (50mm² for 80A,100A)
- 16mm² - Flexible (35mm² for 80A, 100A)

Accessories

- MZ201, MZ202, MZ203, MZ204, MZ206, MZN175, LZ060
- CZ001 for CDA2xxT and CDA4xxT
- MZN121 for others

Standards

- All types conform with AS/NZS 61008.1
- Type F compliant to IEC62493

Technical information: [Page 276](#)



RCCB 1P+N Type F

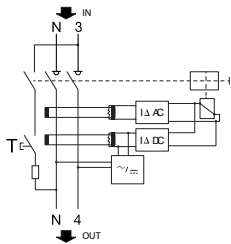

Current rating (A)	Residual current I _{dn}	Module(s)	Width (mm)	Cat ref.
40A	30mA	2 mod	35	CDF540T
63A	30mA	2 mod	35	CDF563T



CDF540T

RCCB 3P+N Type F

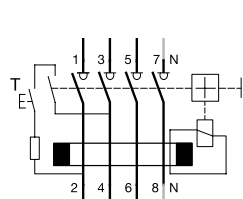

Current rating (A)	Residual current I _{dn}	Modules	Width (mm)	Cat ref.
40A	30mA	4 mod	70	CDF640T
63A	30mA	4 mod	70	CDF663T



CDF640T

Modular Protection devices

Description

Residual Current Circuit Breaker (RCCB) or 'Safety Switches' are designed to open a protected circuit automatically when the circuit leaks current to earth, greater or equal to the devices rated tripping current.

For use in residential, commercial or industrial installations.

Type B

Type B RCCB or 'Safety Switch' is used where earth fault waveform is sinusoidal AC, pulsating DC or smooth DC (VSD applications, lifts, medical equipments, etc).

- Can handle mixed frequency AC currents up to 1000Hz
- AC and/or pulsating currents with DC components
- Direct earth fault currents up to 10mA
- Earth fault current generated by a rectifier.

Features

- Earth fault indication window
- Line circuit is connected on top and load on bottomT
- Polarity sensitive

Connection capacity

- 25mm² - Rigid
- 16mm² - Flexible
- CDBxxx incompatible with KDNxxx busbar

Accessories

- MZ201, MZ202, MZ203, MZ204, MZ206, MZN175, MZN121

Standards

- Compliant to IEC61008.1, AS/ZS61008.1 and IEC62423

Technical information: [Page 277](#)



CDB540T

RCCB 1P+N Type B

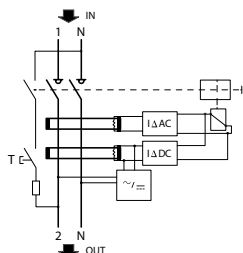

Current rating (A)	Residual current I _{dn}	Module(s)	Width (mm)	Cat ref.
25A	30mA	4 mod	70	CDB525T
40A	30mA	4 mod	70	CDB540T
63A	30mA	4 mod	70	CDB563T



CDB640T

RCCB 3P+N Type B

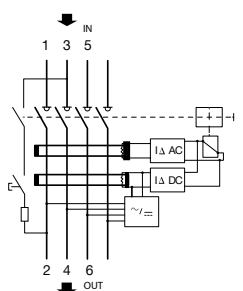

Current rating (A)	Residual current I _{dn}	Module(s)	Width (mm)	Cat ref.
25A	30mA	4 mod	70	CDB625T
40A	30mA	4 mod	70	CDB640T
63A	30mA	4 mod	70	CDB663T

Accessories compatible for all RCBOs

- MZN175

Accessories compatible for AxM4xxT, AxA5xxT and AxX4xxT RCBOs only

- MZ201, MZ202, MZ203, MZ204, MZ206

Accessories compatible for all RCCBs

- CZ001, MZ201, MZ202, MZ203, MZ204, MZ206, MZN175

Combination Auxiliary & Alarm Switch

If shunt trip or undervoltage release is required, the CZ001 must be used as a coupler for RCCBs (CDA2xxT and CDA4xxT)

Connection

- 10mm² rigid
- 6mm² flexible

Compatibility chart and technical information: [Page 278](#)

Accessories

Description	Characteristics	Module(s)	Width (mm)	Cat. ref.
Combination auxiliary & alarm contacts Allows remote indication of main contact status and indicates a fault condition (eg Safety Switch tripped) for RCCBs (CDA2xxT & CDA4xxT).	2 x (1NO + 1NC) 6A-240V~	1	17.5	CZ001
Auxiliary contacts Allows remote indication of main contact status for RCBOs and RCCBs (CxA5xxT & CxA6xxT).	6A - 240V~ 1NO + 1NC	0.5	8.75	MZ201
Alarm contacts indicates a fault over current on overload or short circuit (e.g. RCBO tripped). For RCBOs and RCCBs (CxA5xxT & CxA6xxT).	6A - 240V~ 1NO + 1NC	0.5	8.75	MZ202
Shunt trip relay Allows remote tripping of (combined) RCD when a voltage is applied.	230V - 415V AC 110V to 130V DC	1	17.5	MZ203
	24V - 48V AC 12V - 48V DC	1	17.5	MZ204
Undervoltage release Trips the (combined) RCD when the voltage falls between 35% and 70% of nominal voltage.	230V AC Coil consumption: 3.5 VA	1	17.5	MZ206
Locking device Allows locking of the device; toggle in the lock on/off position; will accept two padlocks with hasps of 4.75mm diameter maximum.	Supplied without padlock	1	17.5	MZN175
Heat dissipation inserts	Avoids overheating for DIN rail modules when several devices mounted side by side are carrying high continuous loads	0.5	8.75	LZ060
Phase barriers for RCCBs (Inc 10kA)	1 set of 3			MZN121



CZ001



MZ202



MZ203



MZN175



LZ060

Modular Protection devices

Modular Circuit Protection

One Module Add-On Block (AOB)

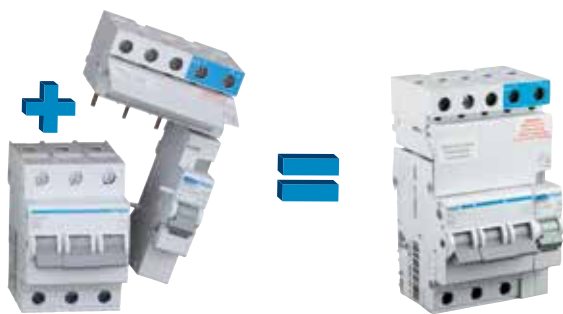

3P MCB + RCD ADD-ON BLOCK

3P+N RCBO

Description

The compact one module wide Add-On Block (AOB) can be used in combination with any Hager 3P MCB up to 63A. The one module RCD Add-On Block + MCB combinations suit all Hager chassis boards including the performa series and invicta panelboards. It is the most compact '3P+N RCBO' for chassis boards.

The RCD Add-On Block + MCB provides protective characteristics of both devices which protects the entire circuit of a panelboard and removes the need to wire between DIN mounted RCD & MCB. This results in reduced time, labour and the size & cost of integrated RCD socket outlets.

The 'Type A' Add-On Block gives the added protection against any 'pulsating DC component' generating from such loads as; power tools, motor speed controllers etc.

The AOB + MCB is suitable for balanced and unbalanced loads. Connection of neutral is required for unbalanced load.

Standards

- Conforms with IEC 61008-1 and AS/NZS 61008.1 when used with a Hager MCB.

Technical information: [Page 279](#)



BD163T

One Module Add-On Block

Description	Residual current I _{dn}	Cat ref.
3 phase earth leakage protection Up to 63A Type A	30mA	BD163T
	100mA	BE163T
	300mA	BF163T

Description

A range of connection devices to simplify installation of modular devices such as MCBs, RCDs etc...

Insulated busbars - Fork type

Description	Module(s)	Width (mm)	Cat ref.
1 phase 80A	12 mod	210	KDN180A
1 phase 80A	18 mod	315	KDN180G
1 phase 100A - bulk	57 mod	1000	KD190B
2 phase 80A	12 mod	210	KDN280A
3 phase 80A	12 mod	210	KDN380A
3 phase 80A	18 mod	315	KDN380G

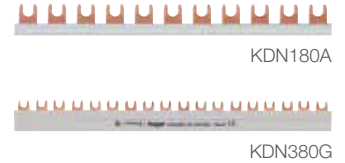

Insulated busbars - Tongue Type

Description	Characteristics	Module(s)	Width (mm)	Cat ref.
1 neutral 80A. Suits neutral supply in onekonekt range of RCBOs	6 tongues over 12 poles	12 mod	210	KB181A1
1 neutral 80A. Suits neutral supply in onekonekt range of RCBOs	9 tongues over 18 poles	18 mod	315	KB181G1



Insulated busbars - Tongue type

Supplied with 10 tongue pole covers

Description	Characteristics	Module(s)	Width (mm)	Cat ref.
1 phase 63A	13 tongues over 13 pole	13 mod	227.5	KB163P
1 neutral 63A	13 tongues over 13 poles	13 mod	227.5	KB163N
1 phase 63A	18 tongues over 18 poles	18 mod	315	KB163PG
1 neutral 63A	18 tongues over 18 poles	18 mod	315	KB163NG

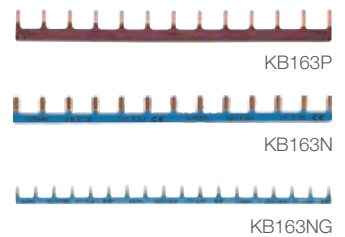

Insulated caps

Description	Characteristics	Quantity	Cat ref.
Busbar end caps	Suits KDN1xx & KB181xx	50	KZN021
Busbar end caps	Suits KDN2xx/KDN3xx	10	KZN023
Busbar fork protective cover	5 pole covers x10		KZ059

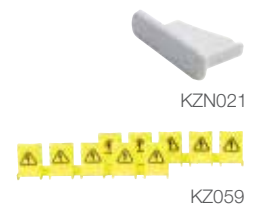

Cable Connectors

Description	Cat ref.
Tongue type connection from top for cables: 25mm ²	KF81A
Tongue type connection from top for cables: 2 x 16mm ²	KF82A
Tongue type connection from side for cables: 35mm ²	KF83A
Tongue type connection from side of cables: 35mm ² with longer tongue	KF83D
Chassis mounted 63A to supply power to the DIN Rail for cables: 25mm ²	KRN163
Chassis or DIN Rail mounted 125A to connect main neutral cable: 50mm ²	KRN199



Other accessories

Description	Characteristics	Cat ref.
RCD neutral links	Brass link for neutral fitting to RCD's: 3 x 10mm ²	KM03A
Cable adaptor - one hole	35mm ² to suit golf enclosure	KM035



Surge Protection for your entire home

Replacing valuable equipment and appliances is costly, so prevention is better than a cure. A typical home contains items such as a TV, home theatre, hi-fi system, computers, gaming consoles, dishwasher, washing machine and a microwave - all of which are susceptible to electrical spikes and surges. Surge protection devices installed in your switchboard protects your valuable equipment at the source.



Surge Protection Devices (SPD) are designed to reduce the risk to electrical installations and connected devices from damage caused by surges, transients from lightning, faults and switching sources.

The risk to a specific installation is determined from a composite of factors such as weather, location, geography and surrounding infrastructure. For definitive requirements for installation of Surge Protection Devices in Australia - please refer to the latest version of AS:1768 and AS:3000.

Cascading

Cascading is the term used to describe the method of combining several levels or types of SPDs into one installation, to create a robust surge protection system. Similar systems and the logic behind them are common to other electrical protection devices. Hager recommends a cascading surge protection system for enhanced voltage regulation, current diverting capacity and reliability.

To simplify selection, Hager uses the terminology: Very Coarse, Coarse, Medium and Fine Surge Protection Devices.

Wiring

SPDs should first be installed at the point of electrical supply (service entrance, incoming mains or sub-mains) on a switchboard, directly after the main switch or isolator, but before other circuit protective devices (especially any RCD or RCBO). Hager SPDs are available to suit installations wired in three phase or single phase.

To gain maximum protection from the SPD, resistance needs to be minimised, conductors used to connect SPD should be kept as short as possible, and the conductor diameter sized appropriately for the application. SPD conductors are oversized to ensure a safe lower resistance path during operation.

Protection against SPD short circuits needs to be provided by an over-current protective device such as a fuse or circuit breaker. This overcurrent device must be suitably rated to discriminate with the SPD - it must permit the flow of surge current without operating. Hager SPD products contain wiring and installation instructions on your choice of fuse or circuit breaker – these are also available at page 283-284.

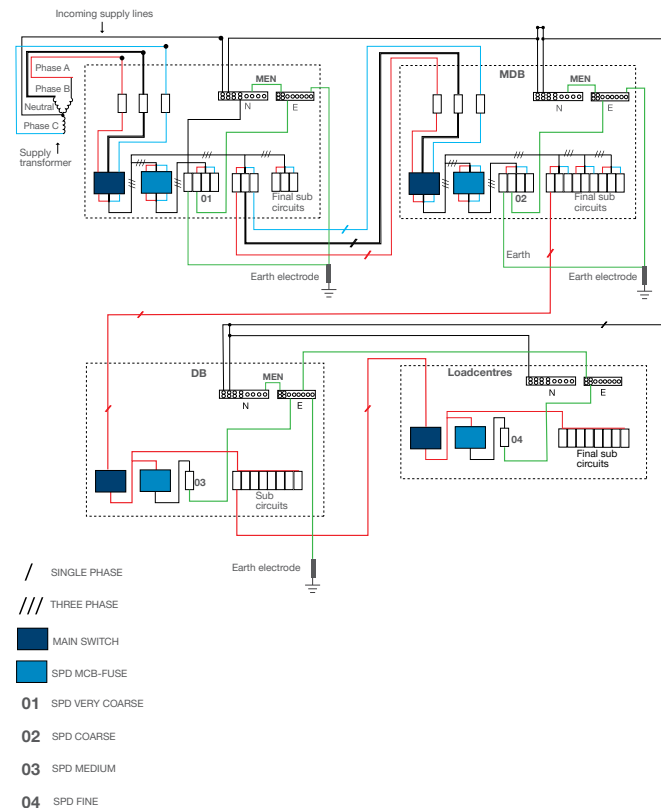

Earthing

The correct selection of the appropriate SPD is based on the location and style of earthing present in the installation, and location of the SPD in the installation.

Hager SPDs are available in two earthing configurations:

1. TNC
2. TNS / TT

The type of earthing most commonly used in low voltage electrical distribution systems in both Australia and New Zealand is referred to as Multiple Earth-Neutral (MEN). When considering a MEN earthing system as a whole, it is treated as a hybrid TN-C-S. (See example diagram below)

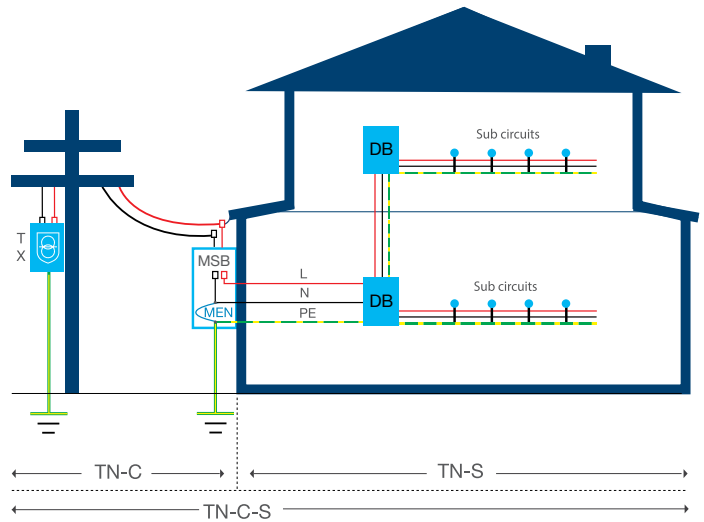

A TN-C earthing system is present between the transformer that supplies the site and the installation MSB, and is used in MEN Switchboard Solutions.

In Australia, a TN-S earthing system is commonly used inside the domestic installations (from the Main Switchboard MEN downstream) and for Separate Neutral-Earth Switchboard Solutions

TN-C-S is comprised of both: The supply side of the system uses a combined Protective Earth Neutral (PEN) conductor for earthing, and the load side (downstream of the MSB) of the system uses a separate conductor for Protective Earth (PE) and Neutral (N).

If the SPD can be located within two meters of the MEN point, select a TN-C type SPD.

Example of TN-C wiring layout:

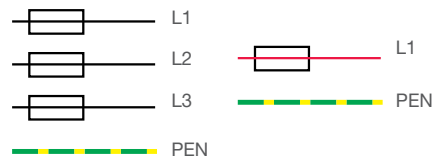

Example of TN-S wiring layout:

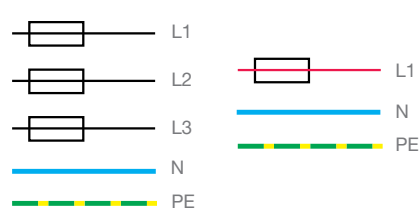

Hager SPD are suitable for 240V SWER, but not suitable for 480V SWER. Select SPD as per the standard TN-C-S system.

Hager provides a simplified four part guide to select appropriate SPDs:

Part 1 - Direct or frequent lightning protection

Lightning has the highest potential for surge damage. The criteria for installing a dedicated lightning protective product is through the following questions:

- Is the installation in a lightning prone area?
- Is the installation adjacent to tall structures, tall trees or near a hill top?
- Does the installation contain a lightning rod?

If the answer is YES to any of the above, Hager recommends installation of a 'Spark Gap' device as the initial component of the SPD system.

Hager offers the SPA range of Spark Gap devices:

- For three phase, the SPA412A
- For single phase, the SPA212A

Part 2 - Indirect Lightning and Transient Protection

To ensure protection of an installation, it is vital to have adequate protection from the harmful effect of indirect or nearby lightning transients. These transients are commonly introduced into an installation from nearby lightning strikes usually from thunder storms.



Thunder Day Map

This map illustrates the lightning activity across Australia and is based upon the 'Thunder Day Map' that appears in AS/NZS 1768. This map is based on Bureau of Meteorology data.

As indicated, Australia is split into three zones of activity.

To choose the appropriate indirect lightning protection, it is important to determine what region the installation is located in:

- 1** Zone 1 - Install **'Coarse'** surge protection and cascading **'Medium'** and **'Fine'** surge protection.
- 2** Zone 2 - Install **'Medium'** surge protection and additional cascaded Fine protection for critical sub circuits
- 3** Zone 3 - Install **'Medium'** surge protection and consider **'Fine'** surge protection for protecting final circuits.

Part 3 - Surrounding infrastructure

Aside from geographic location, the type of installation and the impact of surrounding infrastructure should be considered. An installation in any of the lightning zones shown may require additional or upgraded protection from non-lightning sources of surge.

- Is the installation supplied by exposed or long power lines or sub-mains? i.e. rural or large commercial estate
- Is the installation near a source of man-made switching transients; power plants or substations, or part of a large industrial or commercial zone with large motors?
- Is the electricity supply unreliable? - are there frequent blackouts or brownouts?

If the answer is YES to any of the above, the SPD system selected in Part 2 should be upgraded to a higher rating.

Part 4 - Fine Protection

By installing supplementary cascaded 'Fine' surge protection, the protection of connected devices and appliances can be ensured. Hager 'Fine' SPDs should only be installed to provide supplementary protection - a higher rated SPD must be installed upstream of 'Fine' protection.

- Is the circuit longer than 10 metres, or does it leave the building? e.g. External signage, garden or pool sheds, pumps, illumination and security systems.
- Does a sub-board or sub-circuit contain expensive or critical electronic devices? e.g. OLED and LED TV's, PCs, NAS, security cameras and alarms, home theatre or high end audio equipment, electronic appliances with variable drives or inverter technology, mobility or medical equipment, battery or EV chargers.

If the answer is YES to any of the above, Hager recommends installing supplementary 'Fine' protection.

- Install a SPB208D for single phase final circuits.
- Install a SPB408D for three phase final circuits.

Example SPD wiring diagrams can be found on page 283.

For definitive requirements for installation of Surge Protection Devices, please refer to the latest version of AS:1768 and AS:3000.

Installation examples:

- **For rural, exposed or dispersed multi-building properties**
A cascading surge protection system should be installed, starting with 'Very Coarse' and a 'Spark Gap' at the Point of Supply / Main Switch Board (MSB), then 'Coarse' for Major Sub-mains and detached buildings, followed by 'Medium' at Distribution Boards or Loadcentres and supplementary 'Fine' for any long sub-circuits that have expensive or critical electronic equipment.
- **For commercial buildings and apartments**
Properties should have cascading surge protection installed, with 'Very Coarse' or 'Coarse' at the MSB, 'Medium' for any Sub-mains or Distribution Boards and ideally supplementary 'Fine' protection in Loadcentres. If SPD installation at the MSB is not possible, a higher rated SPD should be considered for the tenancy point of supply.
- **For urban residential and light commercial premises**
For urban and suburban houses or small retail premises. Hager recommends 'Medium' protection at the MSB – however in zones with increased lightning exposure or proximity to industrial and commercial sites, upgrading to 'Coarse' protection with cascading is recommended.

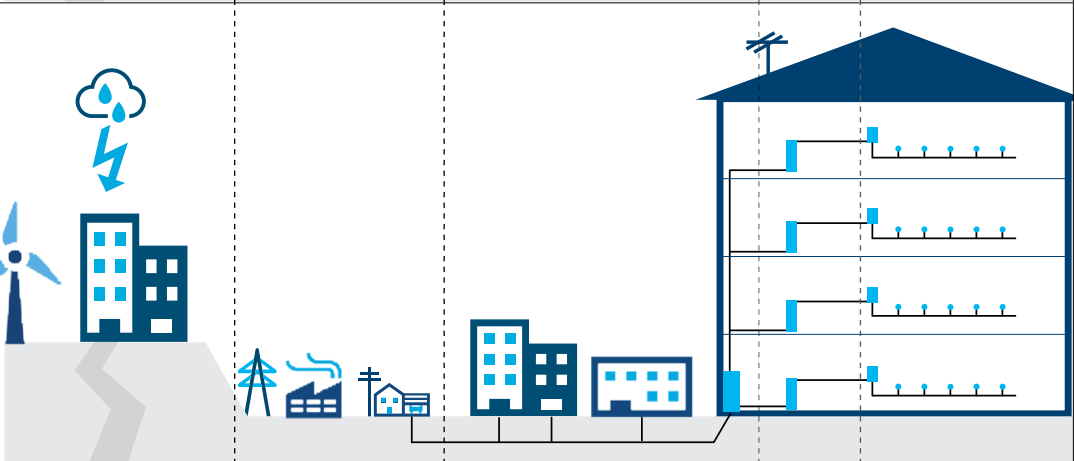
<p>Residential applications</p> 										
<p>Commercial and institutional applications</p> 										
<p>Type of Installation</p>	<p>Very Coarse</p> <ul style="list-style-type: none"> - Highly exposed to lightning - Point of supply entry for highly exposed, lightning prone sites including on hills and ridges, by tall trees or structures or connected by long overhead service power lines - Any installation with a Lightning Rod, LPS or Spark Gap Device - Proximity to very large motors or transformers; usually industrial sites, power plants or substations 		<p>Coarse</p> <ul style="list-style-type: none"> - Somewhat exposed to lightning - Proximity to industrial or large commercial sites that have or induce transients from large transformers or motors. - Or supplied by long service supply cables including private power poles - Rural, Commercial or Large Institutional - Power lines: metering box, point of connection, private power pole 		<p>Medium</p> <ul style="list-style-type: none"> - Rarely exposed to lightning with underground service entrance, and short distance to neighbours - Suitable for most subtropical urban and suburban homes and domestic applications - Suitable for cascaded use, downstream of higher rated SPDs such as in: Major Sub-mains, Distribution Boxes or Load Centres. - Available with (R) or without (D) contact for condition monitoring 		<p>Fine</p> <ul style="list-style-type: none"> - Supplementary protection for final circuits with expensive, critical or important equipment - Load centres and equipment on long circuits or remote from other SPDs - Residential apartments or flats with computer, audio visual, measurement, security, laboratory and scientific equipment 			
<p>Type of Surge Protection</p>	<p>Type 1 Spark Gap Type 2 100kA</p>		<p>Type 2 65kA</p>		<p>Type 2 40kA</p>		<p>Type 2 8kA</p>			
<p>Spark Gap Direct or frequent lightning protection</p>	<p>Three phase SPA412A</p>	<p>Single phase SPA212A</p>	<p>Three phase -</p>	<p>Single phase -</p>	<p>Three phase -</p>	<p>Single phase -</p>	<p>Three phase -</p>	<p>Single phase -</p>	<p>Three phase -</p>	<p>Single phase -</p>
<p>TN-C Used at or near the service supply point and MSB. If the SPD can be located within two meters of the MEN point, select a TN-C type surge protection device.</p>	<p>SPB300R</p>	<p>SPB100R</p>	<p>SPB365R</p>	<p>SPB165R</p>	<p>SPB340D</p>	<p>SPB340R</p>	<p>SPB140D</p>	<p>SPB140R</p>	<p>-</p>	<p>-</p>
<p>TN-S / TT Used after or downstream from the MSB or Switchboard MEN and in separate Neutral-Earth switchboard solutions.</p>	<p>SPB400R</p>	<p>SPB200R</p>	<p>SPB465R</p>	<p>SPB265R</p>	<p>SPB440D</p>	<p>SPB440R</p>	<p>SPB240D</p>	<p>SPB240R</p>	<p>SPB408D</p>	<p>SPB208D</p>

Description

Our SPBxxx devices protect electrical and electronic equipment against transients originating from lightning and switching sources. These transients can cause premature aging of equipment, logic failures and down time, to the complete destruction of electrical components.

Installation and connection

- Very Coarse, Coarse, Medium and Fine
- Spark Gap and MOV technology
- Single phase or Three phase
- TN-C or TN-S / TT
- Part numbers ending in 'R' have a contact to allow for wiring in alarm to indicate cartridge replacement.
- Part numbers ending in 'D' have no contact.
- Replacement NE & L-PE cartridges available

Note

- SPBxxx cartridges are not compatible with legacy SPNxxx products
- **Contact wiring is different from SPNxxxR models to new SPBxxxR models**

Technical information:

[Page 280](#)



SPA212A



SPA412A

Spark Gap

Category C3 (Type 1)

Description	i_{imp} kA	U_p kV	U_c V	Width	Cat ref.
For areas where lightning is frequent.	12.5	≤ 2.5	255	4 mod	SPA212A
Test wave 10/350 μ s	12.5	≤ 2.5	255	8 mod	SPA412A

Both the SPA212A & SPA412A have dual earth and phase / neutral terminals.

Devices are connected in both common and differential modes (L-E/NE/L-N) together with inbuilt auto protection up to 12.5kA.



SPB100R



SPB400R

Very Coarse

Category C2 (Type 2) - Supplied with remote contact

Description	i_{Max} kA	I_n kA	U_p kV	U_c V	Width	Cat ref.
Single phase						
SPD 1P T2 TNC 100kA Remote contact	100	40	2	320	1 mod	★ SPB100R
SPD 2P T2 TNS/TT 100kA Remote contact	100	40	2	320	2 mod	★ SPB200R
Three phase						
SPD 3P T2 TNC 100kA Remote contact	100	40	2	320	3 mod	★ SPB300R
SPD 4P T2 TNS/TT 100kA Remote contact	100	40	2	320	4 mod	★ SPB400R



SPB165R



SPB465R

Coarse

Category C2 (Type 2) - Supplied with remote contact

Description	i_{imp} kA	i_{Max} kA	I_n kA	U_p kV	U_c V	Width	Cat ref.
Single phase							
SPD 1P T2 TNC 65kA Remote contact	12.5	65	20	1.45	320	1 mod	✗ SPN165R → ★ SPB165R
SPD 2P T2 TNS/TT 65kA Remote contact	12.5	65	20	1.45	320	2 mod	★ SPB265R
Three phase							
SPD 3P T2 TNC 65kA Remote contact	12.5	65	20	1.45	320	3 mod	★ SPB365R
SPD 4P T2 TNS/TT 65kA Remote contact	12.5	65	20	1.45	320	4 mod	★ SPB465R

Description

Our SPBxxx devices protect electrical and electronic equipment against transients originating from lightning and switching sources. These transients can cause premature aging of equipment, logic failures and down time, to the complete destruction of electrical components.

Installation and connection

- Very Coarse, Coarse, Medium and Fine
- Spark Gap and MOV technology
- Single phase or Three phase
- TN-C or TN-S / TT
- Part numbers ending in 'R' have a contact to allow for wiring in alarm to indicate cartridge replacement.
- Part numbers ending in 'D' have no contact.
- Replacement L-N cartridges available

Note

- SPBxxxx cartridges are not compatible with legacy SPNxxxx products
- **Contact wiring is different from SPNxxxR models to new SPBxxxR models**

Technical information:
[Page 281](#)

Medium

Category B and C1 (Type 2)

Description	iMax kA	In kA	Up kV	Uc V	Width	Cat ref.
Single phase						
SPD 1P T2 TNC 40kA	40	20	1.35	275	1 mod	x SPN140D → ★ SPB140D x SPN115D
SPD 1P T2 TNC 40kA Remote contact	40	20	1.35	275	1 mod	x SPN140R → ★ SPB140R x SPN115R
SPD 2P T2 TNS/TT 40kA	40	20	1.35	275	2 mod	★ SPB240D
SPD 2P T2 TNS/TT 40kA Remote contact	40	20	1.35	275	2 mod	★ SPB240R
Three phase						
SPD 3P T2 TNC 40kA	40	20	1.35	275	3 mod	★ SPB340D
SPD 3P T2 TNC 40kA Remote contact	40	20	1.35	275	3 mod	★ SPB340R
SPD 4P T2 TNS/TT 40kA	40	20	1.35	275	4 mod	★ SPB440D
SPD 4P T2 TNS/TT 40kA Remote contact	40	20	1.35	275	4 mod	★ SPB440R



SPB140D



SPB440R

Fine

Category A (Type 2) - Supplied without remote contact

Description	iMax kA	In kA	Up kV	Uc V	Width	Cat ref.
Single phase						
SPD 2P TNS/TT 8 kA	8	2	0.9	275	2 mod	x SPN208D → ★ SPB208D
Three phase						
SPD 4P TNS/TT 8 kA	8	2	0.9	275	4 mod	x SPN408D → ★ SPB408D



SPB208D



SPB408D

Description

Our SPBxxxx replacement cartridges and bases are IP2X. This allows for simple 'hot swap' remove and replacement of expended cartridges.

- SPD cartridges should be replaced when the visual indicator changes to a distinct 'Red'.
- Replacement cartridges are available for all different ratings and types
- A keying system exists to prevent a line (L-N) cartridge being interchanged by mistake with a neutral one (N-PE) and vice versa.

- Three phase SPD requires 3x L-N
- SPBxxxx cartridges are not compatible with legacy SPNxxxx products
- **SPD 'R' model contactor wiring layout has changed for all new SPBxxxR SPDs**

Technical information:
[Page 282](#)



SPB065R

SPB Replacement Active Cartridges - L-N

For TN-S and TN-C SPD

Description	Type	iMax kA	Cat ref.
Cartridge L-N; In 40kA, I _{max} 100kA	Very Coarse	100	★ SPB010R
Cartridge L-N; In 20kA, I _{max} 65kA	Coarse	65	★ SPB065R
Cartridge L-N; In 20kA, I _{max} 40kA	Medium	40	★ SPB040R
Cartridge L-N; In 2kA, I _{max} 8kA	Fine	8	★ SPB008R



SPB008D

Modular Protection devices



SPB010N

SPB Replacement Neutral Cartridges - N-PE

For TN-S SPD

Description	Type	iMax kA	Cat ref.
Cartridge N-PE; In 20kA, I _{max} 100kA	Very Coarse	100	★ SPB010N
Cartridge N-PE; In 20kA, I _{max} 65kA	Coarse	65	★ SPB065N
Cartridge N-PE; In 20kA, I _{max} 40kA	Medium	40	★ SPB040N



SPB040N

Description

Protection and control of circuits against overloads and short circuits suitable for Fuses which comply with BS88: Part I:1998

Technical data

- Rated voltage:
415V AC
250V DC
- Fusing factor: class Q1
- Rated breaking capacity:
80kA at 415V AC
40kA at 250V DC
- Fuse cartridge not supplied

Connection capacity

- 16mm² rigid cable
- 16mm² flexible + busbar

Technical information:

[Page 285](#)

Fuses & Fuse Carriers

Description	Current rating (A)	Width	Cat. ref.
Fuse carriers for BS88 fuses (supplied without fuse cartridge)	32A max	1 mod	LS201
BS88 cartridge fuses 29 x 12.7mm	6A		L17300
	8A		L17400
	10A		L17500
	16A		L17600
	20A		L17700
	25A		L17800
	32A		L17900



LS201

Accessories

Description	Width	Cat. ref.
Handle link pin	3 mod	L023
Spare fuse holder (DIN mounted)	1 mod	L14700
Locking kit		MZ178



L14700

Fault loop impedance

With the introduction of AS/NZS 3000:2018 there are new wiring rules for electrical contractors and electrical consultants to consider when designing an electrical installation.

This guide is only concerned with one new area, fault loop impedance, and it's affect on the choice of conductor and circuit breaker for a given circuit. Voltage drop and overcurrent requirements should also be given consideration.

An earth fault situation is caused when an active conductor comes into contact with an earthed conductor - fault current then flows. Contractors and consultants must make sure that the conductors in a circuit will allow sufficient energy to flow to cause the circuit breaker to trip in the required time (disconnection time for 230V supply is 0.4s for socket-outlets up to 63A, or handheld Class 1 equipment intended for manual movement during use. 5 seconds for other circuits including submains and final sub circuits supplying fixed or stationary equipment (clause 1.5.5.3)

To make sure that this fault current is large enough to trip a circuit breaker in the required time the fault loop impedance (Z_s) must be below a certain value. If Z_s is too large then the circuit breaker may take too long to trip (> 0.4s) or may not trip at all.

The tables below are a guide to the maximum circuit length for a given Hager circuit breaker. Using these tables will help ensure that the disconnection time for a 230V a.c. supply is met according to AS/NZS 3000:2018.

Conductor size		Protective device rating	Hager circuit breaker (AS/NZS60898)	
Active	Earth		Type C	Type D
mm2	mm2	A	MCL (max circuit length in meters)	
1	1	6	91	55
1	1	10	55	33
1.5	1.5	10	82	49
1.5	1.5	16	51	31
2.5	2.5	16	85	51
2.5	2.5	20	68	41
4	2.5	25	67	40
4	2.5	32	52	31
6	2.5	40	48	29
10	4	50	62	37
16	6	63	76	45
16	6	80	59	36
25	6	80	66	40
25	6	100	53	32
35	10	100	85	51
35	10	125	68	41
50	16	125	106	63
50	16	160	83	50
70	25	160	126	75
70	25	200	100	60

Maximum circuit length (MCL) and maximum circuit impedance (Z_s) for Hager MCBs (MSNxxx, NTxxxC & NDNxxxA ranges).

Where: MCL = Maximum circuit length

Above table based on supply of voltage of 230V / 400V (AS/NZS 3000:2018)

- Circuit length: Circuit impedance increases with the length of a circuit.
- Cross-sectional area of cable: The smaller the cross-sectional area of a cable, the higher it's impedance per meter will be.
- Thermal and magnetic settings of a circuit breaker: Hager circuit breakers have both rated current and magnetic characteristics.

The higher the rated current and magnetic settings, the more energy is required to trip the circuit breaker in the required time (< 0.4 s). So a circuit breaker with a magnetic setting of $14 \times I_n$ will require more energy to trip it (in the required time) than a circuit breaker with a magnetic setting of $7.5 \times I_n$.

If more energy is required to flow, then a larger cross-sectional area cable may be needed. If this is not possible then installing a Hager RCD will provide a simple and economical solution.

So circuit length, cross sectional area of the cable and circuit breaker settings all need to be taken into account to ensure correct function of a circuit.

Calculation of Prospective Short Circuit Current

Several excellent proprietary computer programs are now available for calculating the prospective fault level at any point in the installation. They are also able to select the correct size and type of cable and match this with the correct circuit protective device.

Estimation of Prospective Fault Current

Actually calculating prospective short-circuit current is not in itself difficult but it does require basic data which is not always available to the electrical installation designer. It is therefore usual to use a simple chart as shown in FIGURE 1 to estimate the prospective short circuit current. This type of chart always gives a prospective fault level greater than that which would have been arrived at by calculation using accurate basic data. Therefore it is safe to use but sometimes may result in an over engineered system.

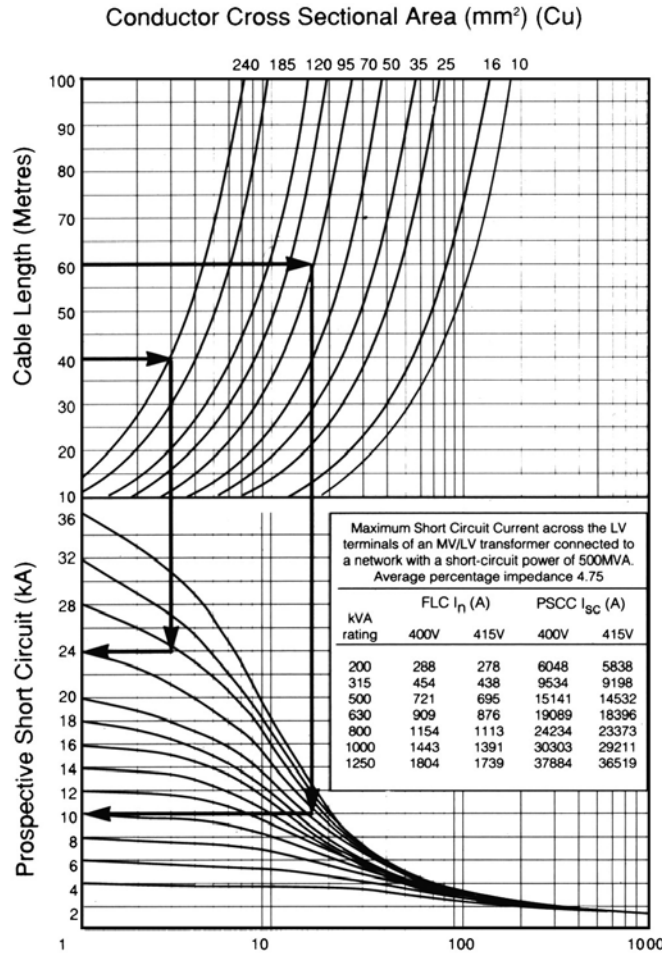

Figure 1

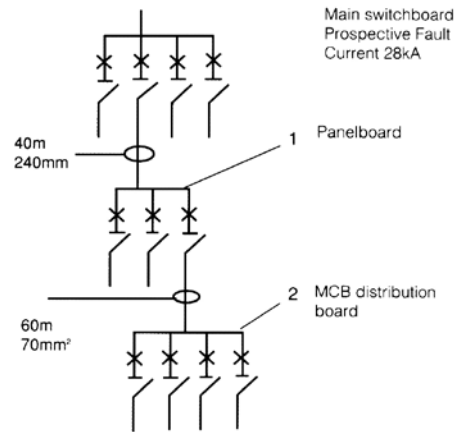

Figure 2

Example in figure 2

- 1 Project 40m of cable length across on to the 240mm² cable curve. From this point project down onto the 28kA curve. From this point projecting across we note that the prospective fault level at the panelboard is 24kA.
- 2 Project 60m of cable length across onto the 70mm² cable curve. From this point project down on to the 24kA curve. From this point projecting across we see that the prospective fault level at the MCB distribution board is 10kA.

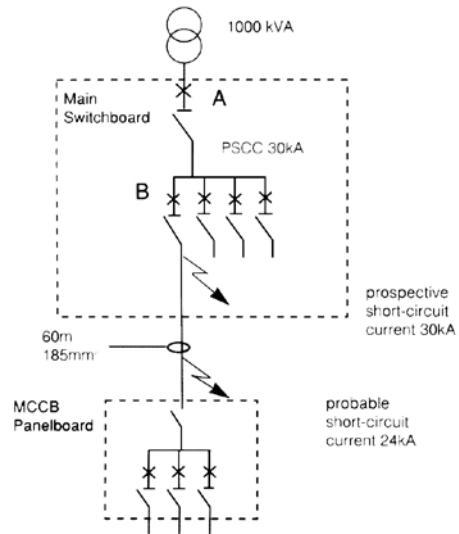
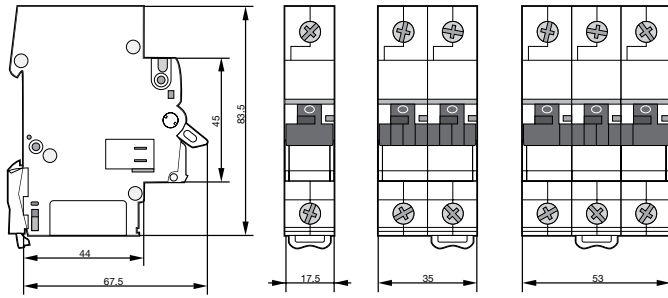

Figure 3

The relationship between probable short-circuit current and service short-circuit breaking capacity is explained. The probable short circuit is the type of short circuit which is most likely to occur; this is nearly always at the extremity of the protected cable and more often than not a single phase or earth fault. Figure 3 shows a typical 3 phase 4 wire 400V system fed by a 1000 kVA transformer. The transformer is adjacent to the main switchboard so the prospective short-circuit current (PSCC*) on the main switchboard busbars is estimated as 30kA. The probable short-circuit current on the panelboard feeder circuit is estimated as 24kA, if it were a 3 phase symmetrical fault, or 12kA for a phase to neutral fault, which in fact would be the most likely type of fault. (Note: when estimating a phase to neutral prospective short-circuit current, the length of conductor is doubled.) Therefore for this application the main switchboard incoming circuit breaker (A) should have an I_{cs} 30kA and an I_{cu} 30kA. The panelboard feeder circuit breaker (B) should have an I_{cu} 30kA and an I_{cs} 24kA.

Dimensions



Specifications

Standards	AS/NZS 60898
Thermal trip characteristic	C curve (5-10 x I _n)
Breaking capacity I_{cn}	6000A
Voltage rating	240/415V AC
Frequency	50-60Hz
Current rating	6A - 63A
No. of operations	20,000
Connection capacity	Rigid 25mm ² max. Flexible 16mm ² max.
Tightening torque	2.8Nm
Toggle	Sealable in Off position
Operating temperature	-25°C to 60°C

Grouping factor	Assumed load factor	
Number of outgoing circuits	2 & 3	0.8
	4 & 5	0.7
	6 to 9	0.6
	10 +	0.5

Tripping curve - All In Tcal= 30°C C curve

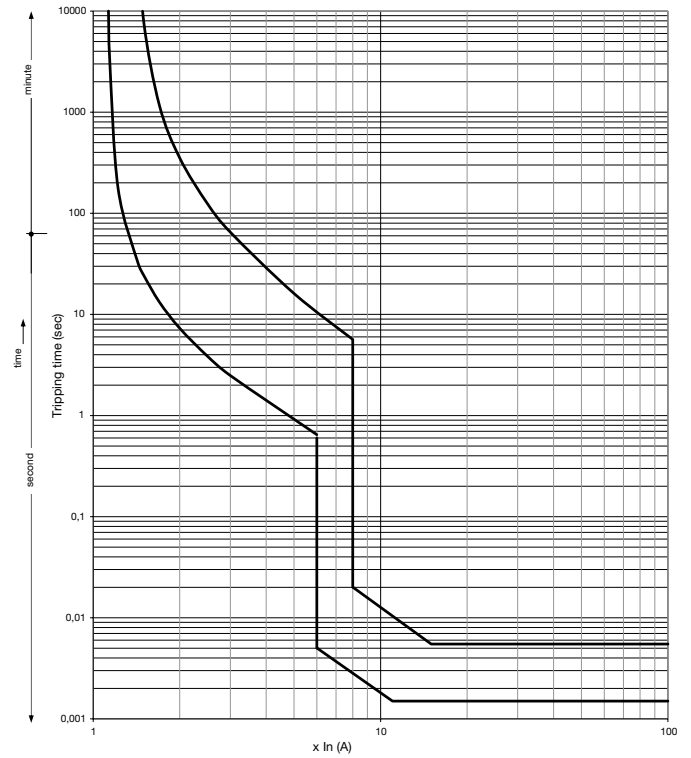

Temperature derating table 1P/2P (calibration temperature 30°C)

Ambiant temp (°C)	Rated current (A)										
	6	8	10	13	16	20	25	32	40	50	63
-25	7.82	9.22	11.14	17.07	21.82	27.36	33.35	41.83	51.36	67.46	83.89
-20	7.67	9.12	10.98	16.72	21.31	26.70	32.58	41.01	50.43	66.02	82.07
-15	7.52	9.01	10.83	16.37	20.81	26.03	31.81	40.18	49.49	64.58	80.24
-10	7.37	8.91	10.50	16.10	20.41	25.40	31.01	39.62	48.53	63.69	78.67
-5	7.21	8.80	10.53	15.67	19.81	24.71	30.27	38.54	47.54	61.71	76.58
0	7.05	8.69	10.38	15.33	19.31	24.05	29.51	37.71	46.54	60.27	74.75
5	6.89	8.58	10.22	14.98	18.81	23.39	28.74	36.89	45.52	58.83	72.93
10	6.72	8.46	10.07	14.63	18.31	22.73	27.97	36.07	44.47	57.40	71.10
15	6.55	8.35	9.92	14.28	17.81	22.07	27.20	35.24	43.39	55.96	69.27
20	6.37	8.24	9.77	13.93	17.31	21.41	26.43	34.42	42.29	54.52	67.44
25	6.19	8.12	9.62	13.59	16.81	20.75	25.66	33.60	41.16	53.09	65.61
30	6	8	10	13	16.00	20	25	32	40	50	63
35	5.81	7.88	9.31	12.89	15.80	19.42	24.13	31.95	38.80	50.21	61.96
40	5.61	7.76	9.16	12.54	15.30	18.76	23.36	31.13	37.57	48.78	60.13
45	5.40	7.63	9.01	12.19	14.80	18.10	22.59	30.31	36.29	47.34	58.30
50	5.18	7.51	8.50	12.00	14.50	17.50	21.75	30.00	34.97	47.00	57.00
55	4.96	7.38	8.70	11.50	13.80	16.78	21.05	28.66	33.59	44.46	54.65
60	4.72	7.25	8.55	11.15	13.30	16.12	20.28	27.84	32.15	43.03	52.82
65	4.47	7.11	8.40	10.80	12.80	15.46	19.51	27.01	30.65	41.59	50.99
70	4.21	6.98	8.25	10.45	12.30	14.80	18.75	26.19	29.07	40.15	49.16

Calibration temperature for MSN140 and MSN163 is 40°C. Please refer to the product data sheet for the temperature derating table.

Temperature derating table 3P (calibration temperature 30°C)

Ambiant temp (°C)	Rated current (A)										
	6	8	10	13	16	20	25	32	40	50	63
-25	6.85	9.18	13.33	16.03	20.42	25.32	31.54	39.93	50.03	63.65	78.38
-20	6.75	9.08	13.06	15.78	20.06	24.89	31.00	39.28	49.20	62.53	76.96
-15	6.66	8.97	12.79	15.52	19.69	24.44	30.46	38.61	48.36	61.40	75.55
-10	6.50	8.87	12.51	15.26	19.32	23.99	29.90	37.93	47.51	60.24	74.06
-5	6.47	8.77	12.22	15.00	18.93	23.53	29.33	37.24	46.63	59.05	72.71
0	6.38	8.66	11.93	14.73	18.54	23.06	28.75	36.54	45.75	57.85	71.30
5	6.28	8.55	11.63	14.46	18.14	22.58	28.16	35.82	44.84	56.62	69.88
10	6.19	8.45	11.32	14.18	17.74	22.09	27.56	35.09	43.91	55.36	68.46
15	6.09	8.34	11.01	13.89	17.32	21.58	26.94	34.35	42.97	54.07	67.05
20	6.00	8.23	10.68	13.60	16.89	21.07	26.31	33.58	42.00	52.75	65.63
25	5.90	8.11	10.35	13.30	16.45	20.54	25.66	32.80	41.01	51.39	64.21
30	6	8	10.00	13.00	16.00	20.00	25	32	40.00	50.00	63.00
35	5.71	7.87	9.63	12.69	15.49	19.36	24.27	31.14	38.76	48.50	61.38
40	5.62	7.74	9.25	12.36	14.97	18.71	23.51	30.25	37.49	46.96	59.97
45	5.52	7.60	8.85	12.03	14.43	18.02	22.73	29.33	36.16	45.36	58.55
50	5.30	7.47	8.44	11.69	13.87	17.31	21.92	28.39	34.79	43.71	57.00
55	5.34	7.33	8.00	11.34	13.28	16.57	21.08	27.41	33.36	41.99	55.72
60	5.24	7.18	7.53	10.98	12.66	15.80	20.21	26.39	31.87	40.19	54.30
65	5.15	7.04	7.04	10.60	12.02	14.99	19.30	25.34	30.30	38.31	52.88
70	5.05	6.89	6.50	10.22	11.34	14.12	18.34	24.24	28.64	36.34	51.47

Dimensions

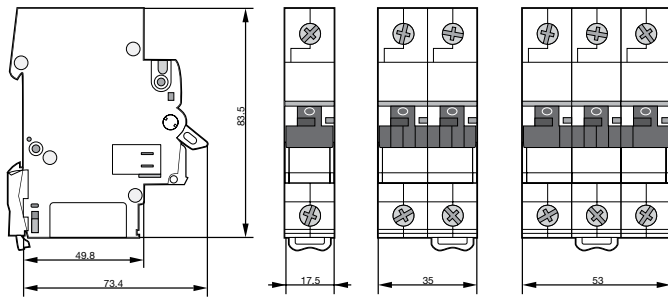

Specifications

Standards	AS/NZS 60898
Thermal trip characteristic	D curve (10-20 x In)
Breaking capacity Icn	6000A
Voltage rating	240/415V AC
Frequency rating	50-60Hz
Current rating	6A - 63A
No. of operations	20,000
Connection capacity	Rigid 35mm ² max. Flexible 25mm ² max.
Tightening torque	2.8Nm
Toggle	Sealable in Off position
Operating temperature	-25°C to 70°C

Grouping factor	Assumed load factor	
Number of outgoing circuits	2	1
	3	0.7
	4 & 5	0.6
	6	0.5

Tripping curve - All In Tcal= 30°C D curve

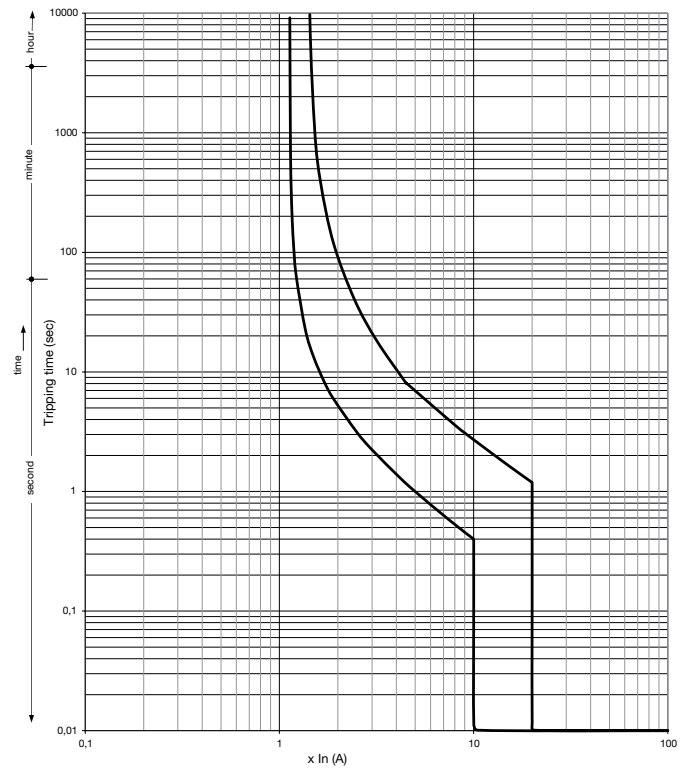

Temperature derating table 1P/2P (calibration temperature 30°C)

Ambiant temp (°C)	Rated current (A)								
	6	10	16	20	25	32	40	50	63
-25	7.82	11.14	21.82	27.36	33.35	41.83	51.36	67.46	83.89
-20	7.67	10.98	21.31	26.70	32.58	41.01	50.43	66.02	82.07
-15	7.52	10.83	20.81	26.03	31.81	40.18	49.49	64.58	80.24
-10	7.37	10.50	20.41	25.40	31.01	39.62	48.53	63.69	78.67
-5	7.21	10.53	19.81	24.71	30.27	38.54	47.54	61.71	76.58
0	7.05	10.38	19.31	24.05	29.51	37.71	46.54	60.27	74.75
5	6.89	10.22	18.81	23.39	28.74	36.89	45.52	58.83	72.93
10	6.72	10.07	18.31	22.73	27.97	36.07	44.47	57.40	71.10
15	6.55	9.92	17.81	22.07	27.20	35.24	43.39	55.96	69.27
20	6.37	9.77	17.31	21.41	26.43	34.42	42.29	54.52	67.44
25	6.19	9.62	16.81	20.75	25.66	33.60	41.16	53.09	65.61
30	6	10	16	20	25	32	40	50	63
35	5.81	9.31	15.80	19.42	24.13	31.95	38.80	50.21	61.96
40	5.61	9.16	15.30	18.76	23.36	31.13	37.57	48.78	60.13
45	5.40	9.01	14.80	18.10	22.59	30.31	36.29	47.34	58.30
50	5.18	8.50	14.50	17.50	21.75	30.00	34.97	47.00	57.00
55	4.96	8.70	13.80	16.78	21.05	28.66	33.59	44.46	54.65
60	4.72	8.55	13.30	16.12	20.28	27.84	32.15	43.03	52.82
65	4.47	8.40	12.80	15.46	19.51	27.01	30.65	41.59	50.99
70	4.21	8.25	12.30	14.80	18.75	26.19	29.07	40.15	49.16

Modular Protection devices

Temperature derating table 3P (calibration temperature 30°C)

Ambiant temp (°C)	Rated current (A)								
	6	10	16	20	25	32	40	50	63
-25	6.85	13.33	20.42	25.32	31.54	39.93	50.03	63.65	78.38
-20	6.75	13.06	20.06	24.89	31.00	39.28	49.20	62.53	76.96
-15	6.66	12.79	19.69	24.44	30.46	38.61	48.36	61.40	75.55
-10	6.50	12.51	19.32	23.99	29.90	37.93	47.51	60.24	74.06
-5	6.47	12.22	18.93	23.53	29.33	37.24	46.63	59.05	72.71
0	6.38	11.93	18.54	23.06	28.75	36.54	45.75	57.85	71.30
5	6.28	11.63	18.14	22.58	28.16	35.82	44.84	56.62	69.88
10	6.19	11.32	17.74	22.09	27.56	35.09	43.91	55.36	68.46
15	6.09	11.01	17.32	21.58	26.94	34.35	42.97	54.07	67.05
20	6.00	10.68	16.89	21.07	26.31	33.58	42.00	52.75	65.63
25	5.90	10.35	16.45	20.54	25.66	32.80	41.01	51.39	64.21
30	6	10	16	20	25	32	40	50	63
35	5.71	9.63	15.49	19.36	24.27	31.14	38.76	48.50	61.38
40	5.62	9.25	14.97	18.71	23.51	30.25	37.49	46.96	59.97
45	5.52	8.85	14.43	18.02	22.73	29.33	36.16	45.36	58.55
50	5.30	8.44	13.87	17.31	21.92	28.39	34.79	43.71	57.00
55	5.34	8.00	13.28	16.57	21.08	27.41	33.36	41.99	55.72
60	5.24	7.53	12.66	15.80	20.21	26.39	31.87	40.19	54.30
65	5.15	7.04	12.02	14.99	19.30	25.34	30.30	38.31	52.88
70	5.05	6.50	11.34	14.12	18.34	24.24	28.64	36.34	51.47

Dimensions

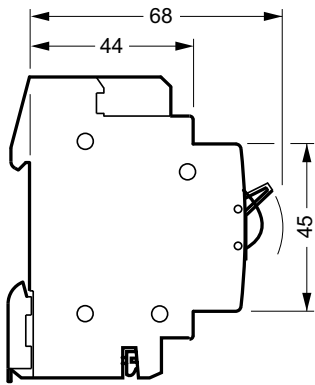

Specifications

Standards	AS/NZS 60898
Thermal trip characteristic	C curve (5-10 x I _n)
Breaking capacity	10,000A
Voltage rating	230/400V AC
Current rating	2A - 63A
No. of operations	20,000
Connection Rigid capacity	35mm ² max.
Flexible capacity	25mm ² max.
Tightening torque	2.8Nm

Auxiliary possibilities

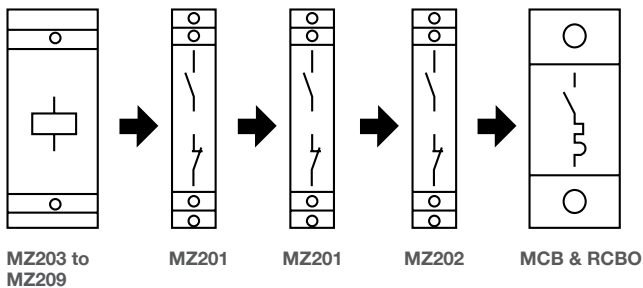

Tripping curve - T_{cal}= 30°C C curve

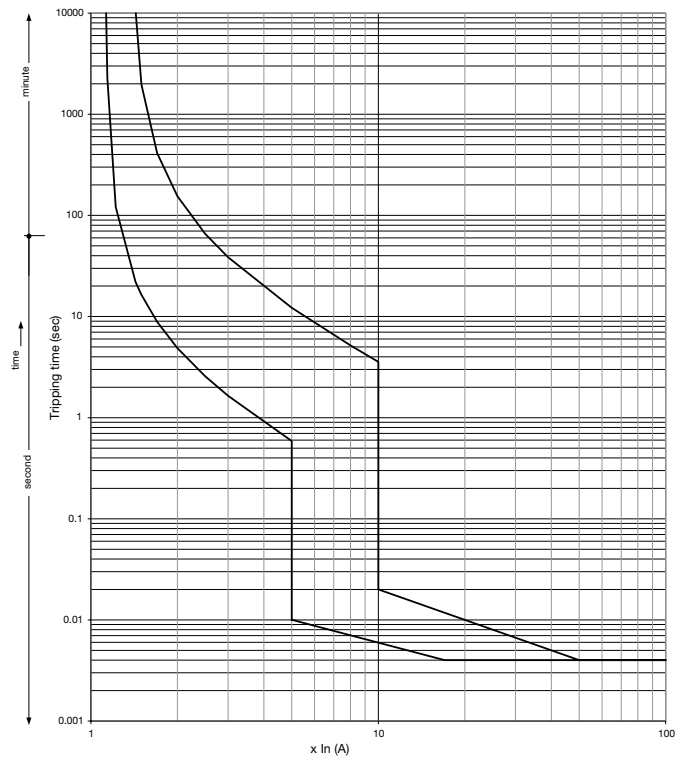

Temperature derating table 1P/2P (calibration temperature 30°C)

Ambiant temp (°C)	Rated current (A)										
	2	4	6	10	16	20	25	32	40	50	63
-25	2.27	4.41	7.17	12.4	20.0	23.8	32.2	38.7	46.8	64.7	81.1
-20	2.25	4.37	7.08	12.2	19.7	23.5	31.6	38.1	46.2	63.5	79.6
-15	2.23	4.34	6.98	12.0	19.3	23.2	31.0	37.5	45.6	62.3	78.1
-10	2.20	4.30	6.87	11.8	19.0	22.8	30.4	37.0	45.0	61.1	76.6
-5	2.18	4.26	6.77	11.6	18.6	22.5	29.8	36.4	44.4	59.9	75.0
0	2.15	4.23	6.67	11.4	18.3	22.2	29.1	35.8	43.8	58.7	73.4
5	2.13	4.19	6.56	11.2	17.9	21.8	28.5	35.2	43.2	57.4	71.8
10	2.10	4.15	6.45	10.9	17.6	21.5	27.8	34.6	42.6	56.1	70.1
15	2.08	4.12	6.34	10.7	17.2	21.1	27.1	33.9	42.0	54.7	68.4
20	2.05	4.08	6.23	10.5	16.8	20.7	26.4	33.3	41.3	53.4	66.7
25	2.03	4.04	6.12	10.2	16.4	20.4	25.7	32.7	40.7	52.0	64.9
30	2	4	6	10	16	20	25	32	40	50	63
35	1.97	3.96	5.88	9.8	15.6	19.6	24.2	31.3	39.3	48.8	62.8
40	1.95	3.92	5.76	9.5	15.2	19.2	23.5	30.6	38.6	47.7	62.6
45	1.92	3.88	5.64	9.2	14.7	18.8	22.7	29.9	37.9	46.5	62.3
50	1.89	3.84	5.51	9.0	14.3	18.4	21.8	29.2	37.2	45.3	62.1
55	1.86	3.80	5.38	8.7	13.8	18.0	21.0	28.5	36.5	44.1	61.9
60	1.83	3.76	5.25	8.4	13.3	17.6	20.0	27.7	35.7	43.0	61.7
65	1.81	3.72	5.13	8.2	12.9	17.2	19.3	27.0	35.1	41.8	61.4
70	1.78	3.68	5.00	7.9	12.4	16.8	18.4	26.3	34.3	40.6	61.2

Modular Protection devices

Temperature derating table 3P (calibration temperature 30°C)

Ambiant temp (°C)	Rated current (A)										
	2	4	6	10	16	20	25	32	40	50	63
-25	2.54	4.64	7.77	12.7	20.5	24.6	31.44	40.79	50.4	64.0	78.9
-20	2.49	4.59	7.62	12.5	20.1	24.3	30.91	40.07	49.6	62.8	77.6
-15	2.45	4.53	7.48	12.3	19.8	23.9	30.37	39.34	48.7	61.7	76.2
-10	2.40	4.48	7.33	12.1	19.4	23.5	29.82	38.59	47.8	60.5	74.9
-5	2.36	4.42	7.18	11.8	19.0	23.1	29.26	37.83	46.9	59.3	73.5
0	2.31	4.36	7.02	11.6	18.6	22.7	28.69	37.06	46.0	58.0	72.1
5	2.26	4.30	6.86	11.3	18.2	22.2	28.11	36.26	45.0	56.8	70.7
10	2.21	4.25	6.70	11.1	17.8	21.8	27.52	35.45	44.1	55.5	69.2
15	2.16	4.19	6.53	10.8	17.3	21.4	26.91	34.62	43.1	54.2	67.7
20	2.11	4.12	6.36	10.6	16.9	20.9	26.29	33.77	42.1	52.8	66.2
25	2.05	4.06	6.18	10.3	16.5	20.5	25.65	32.90	41.1	51.4	64.6
30	2	4	6	10	16	20	25	32	40	50	63
35	1.94	3.94	5.81	9.7	15.5	19.5	24.33	31.08	38.9	48.5	61.4
40	1.89	3.87	5.62	9.4	15.0	19.0	23.64	30.13	37.8	47.0	59.7
45	1.83	3.81	5.42	9.1	14.5	18.5	22.93	29.15	36.6	45.5	57.9
50	1.76	3.74	5.21	8.8	14.0	18.0	22.20	28.13	35.4	43.8	56.1
55	1.70	3.67	4.99	8.5	13.5	17.5	21.44	27.08	34.2	42.1	54.3
60	1.63	3.60	4.77	8.1	12.9	16.9	20.66	25.98	32.9	40.4	52.4
65	1.58	3.54	4.57	7.8	12.4	16.4	19.96	25.02	31.8	38.9	50.7
70	1.51	3.47	4.36	7.5	11.9	15.9	19.23	24.00	30.6	37.2	48.9

NDNxxxA dimensions

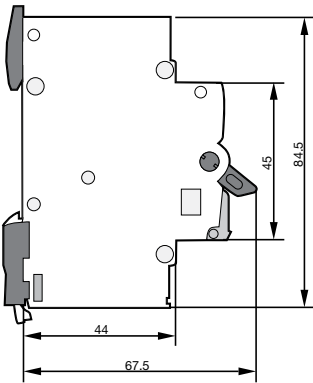

Specifications

Standards	AS/NZS 60898
Thermal trip characteristic	D curve (10-20 x In)
Breaking capacity	10,000A
Voltage rating	240/415V AC
Current rating	6A - 63A
No. of operations	20,000
Connection capacity	Rigid 35mm ² max. Flexible 25mm ² max.
Tightening torque	2.8Nm

Grouping factor	Assumed load factor	
Number of outgoing circuits	2 & 3	0.8
	4 & 5	0.7
	6 to 9	0.6
	10 +	0.5

Tripping curve - All In Tcal= 30°C D curve

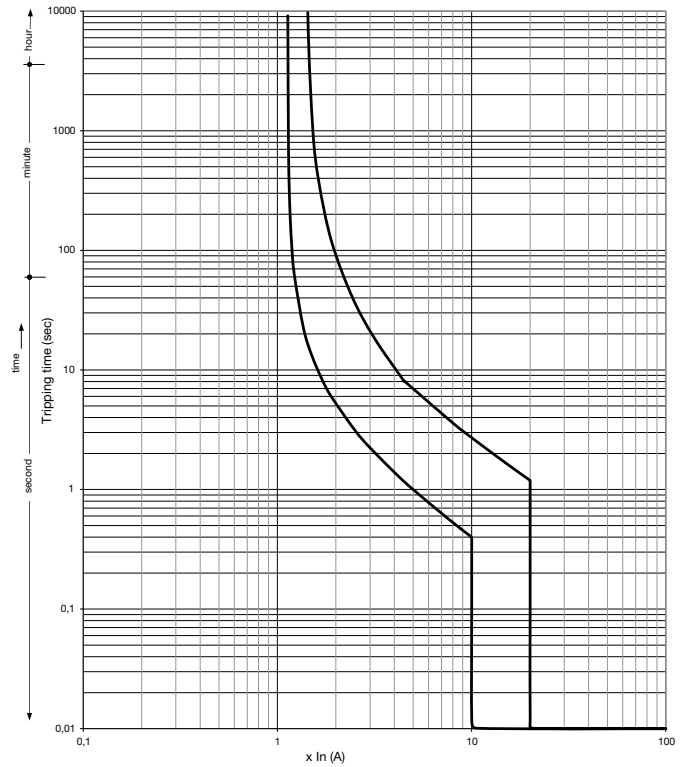

Temperature derating table 1P/2P (calibration temperature 30°C)

Ambient temp (°C)	Rated current (A)										
	2	4	6	10	16	20	25	32	40	50	63
-25	2.67	5.18	7.51	12.9	20.5	25.08	31.41	39.5	51.3	65.1	81.0
-20	2.62	5.09	7.39	12.6	20.1	24.66	30.89	38.9	50.4	63.9	79.6
-15	2.56	4.99	7.26	12.4	19.7	24.24	30.35	38.2	49.5	62.6	78.1
-10	2.51	4.89	7.13	12.1	19.4	23.80	29.80	37.6	48.5	61.4	76.5
-5	2.45	4.79	7.00	11.9	19.0	23.36	29.24	37.0	47.5	60.1	75.1
0	2.39	4.68	6.87	11.6	18.6	22.91	28.68	36.3	46.5	58.9	73.5
5	2.33	4.58	6.73	11.4	18.2	22.45	28.10	35.6	45.5	57.7	72.0
10	2.27	4.47	6.59	11.1	17.8	21.98	27.51	34.9	44.5	56.5	70.5
15	2.20	4.35	6.45	10.9	17.3	21.51	26.90	34.2	43.5	55.3	69.0
20	2.14	4.24	6.30	10.6	16.9	21.02	26.28	33.5	42.4	54.0	67.5
25	2.07	4.12	6.15	10.3	16.5	20.51	25.65	32.8	41.4	52.8	65.9
30	2	4	6	10	16	20	25	32	40	50	63
35	1.93	3.87	5.84	9.7	15.5	19.47	24.33	31.2	39.0	49.4	62.0
40	1.85	3.74	5.68	9.4	15.0	18.93	23.65	30.4	37.9	48.2	60.5
45	1.77	3.61	5.52	9.1	14.5	18.37	22.94	29.6	36.7	46.7	58.7
50	1.69	3.47	5.35	8.7	14.0	17.80	22.21	28.8	35.8	47.0	58.3
55	1.60	3.33	5.17	8.4	13.5	17.20	21.46	27.9	33.6	42.8	52.8
60	1.51	3.17	4.99	8.0	12.9	16.58	20.68	27.0	32.2	40.3	50.5
65	1.41	3.01	4.80	7.6	12.3	15.94	19.87	26.1	30.7	37.6	48.1
70	1.31	2.85	4.60	7.2	11.7	15.28	19.02	25.2	29.1	34.5	45.6

Modular Protection devices

Temperature derating table 3P (calibration temperature 30°C)

Ambiant temp (°C)	Rated current (A)										
	2	4	6	10	16	20	25	32	40	50	63
-25	2.59	4.88	7.61	12.7	20.3	24.8	31.04	39.04	55.3	63.0	78.7
-20	2.54	4.80	7.48	12.5	19.9	24.4	30.54	38.45	54.1	61.9	77.4
-15	2.50	4.73	7.35	12.3	19.6	24.0	30.03	37.86	52.8	60.9	76.1
-10	2.45	4.65	7.21	12.0	19.2	23.6	29.51	37.25	51.6	59.7	74.7
-5	2.39	4.58	7.07	11.8	18.8	23.2	28.99	36.64	50.3	58.6	73.4
0	2.34	4.50	6.93	11.6	18.5	22.7	28.45	36.01	48.9	57.5	72.0
5	2.29	4.42	6.78	11.3	18.1	22.3	27.91	35.37	47.5	56.3	70.6
10	2.23	4.34	6.63	11.1	17.7	21.9	27.35	34.73	46.1	55.1	69.1
15	2.18	4.26	6.48	10.8	17.3	21.4	26.78	34.06	44.7	53.9	67.6
20	2.12	4.17	6.32	10.5	16.9	21.0	26.20	33.39	43.2	52.6	66.1
25	2.06	4.09	6.16	10.3	16.4	20.5	25.61	32.70	41.6	51.3	64.6
30	2	4	6	10	16	20	25	32	40	50	63
35	1.93	3.90	5.81	9.6	15.5	19.5	24.23	31.26	38.0	48.5	61.0
40	1.85	3.79	5.61	9.2	14.9	18.9	23.44	30.50	35.8	46.9	58.9
45	1.77	3.69	5.41	8.8	14.4	18.4	22.61	29.72	33.5	45.3	56.7
50	1.69	3.58	5.19	8.3	13.8	17.8	21.76	28.92	31.0	43.6	54.4
55	1.61	3.46	4.97	7.9	13.2	17.2	20.87	28.10	28.3	41.9	52.0
60	1.51	3.34	4.74	7.4	12.6	16.6	19.94	27.26	25.4	40.0	49.6
65	1.42	3.22	4.50	6.8	11.9	16.0	18.97	26.38	22.0	38.1	46.9
70	1.31	3.10	4.24	6.2	11.2	15.3	17.94	25.48	18.0	36.1	44.2

HMF / HMC / HMD dimensions

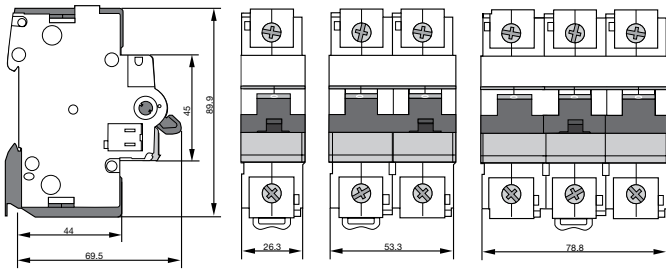

Specifications	HMFxxT	HMCxxT	HMDxxT
Standards	AS/NZS 60898	AS/NZS 60898	AS/NZS 60898
Thermal trip characteristic	C curve (5-10 x I _n)	C curve (5-10 x I _n)	D curve (10-20 x I _n)
Breaking capacity	10,000A	15,000A	15,000A
Voltage rating	240/415V AC	240/415V AC	240/415V AC
Current rating	80A - 125A	80A - 125A	80A - 125A
No. of operations	20,000	20,000	20,000
Rigid connection	70mm ² max.	70mm ² max.	70mm ² max.
Flexible connection	35mm ² max.	35mm ² max.	35mm ² max.
Tightening torque	3.5 to 5Nm	3.5 to 5Nm	3.5 to 5Nm

Derating table

Ambiant temp (°C)	T° cal = 30°C: Rated current (A)		
	80	100	125
-25	115.0	-	-
-20	112.0	-	-
-15	109.0	-	-
-10	106.0	-	-
-5	102.0	-	-
0	99.2	124.0	-
5	96.0	120.0	-
10	92.8	116.0	-
15	89.6	112.0	-
20	86.4	108.0	-
25	83.2	104.0	-
30	80	100	125
35	77.6	96.6	122.0
40	75.1	93.1	119.0
45	72.6	89.4	115.7
50	70.0	85.6	112.0
55	67.2	81.6	109.1
60	64.3	77.5	105.6
65	-	-	-
70	-	-	-

Modular Protection devices

Tripping curve - HMF / HMC - C curve 80A - Tcal= 30°C

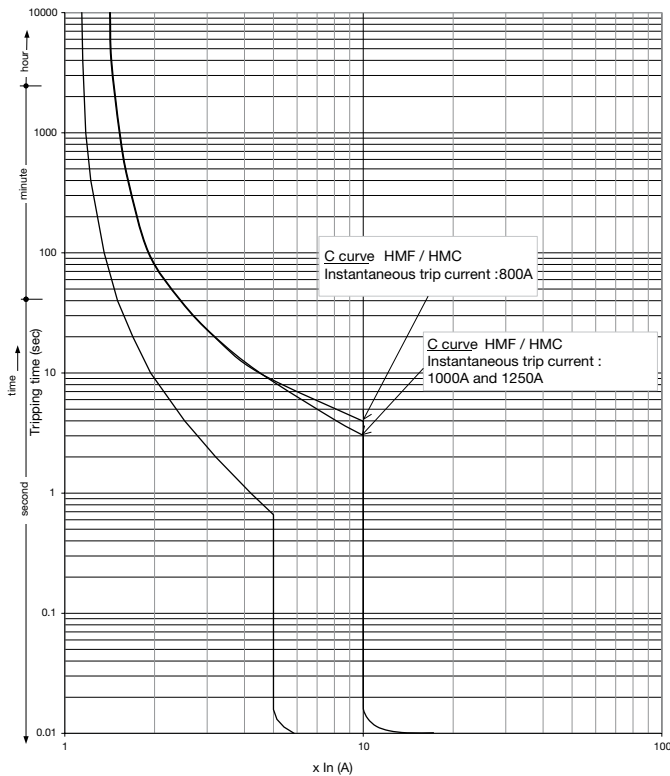

Tripping curve - HMD - D curve 80A - Tcal= 30°C

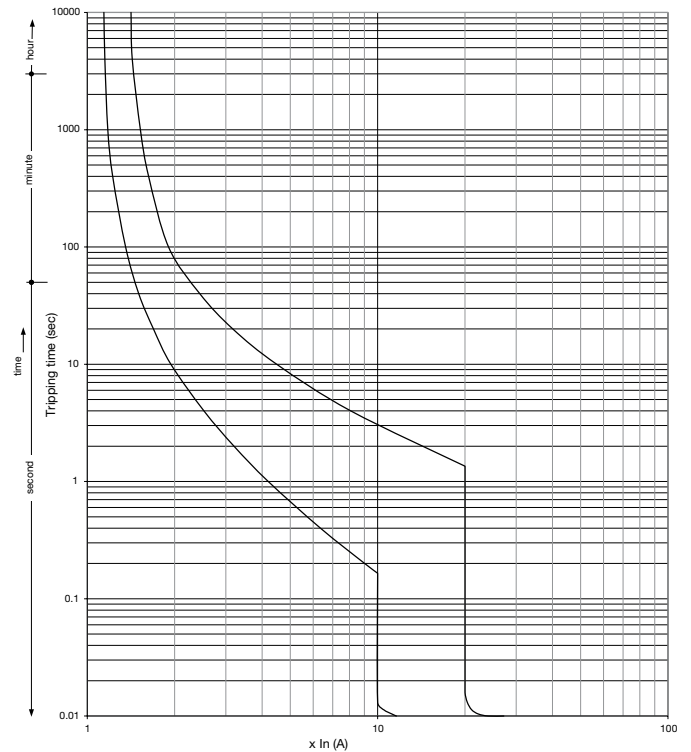

ADC9 RCBO



A compact solution for every situation

Our ADC9xxT RCBO or 'onekombo' is only one module wide, making it ideal for retrofit installations where space can be limited. onekombo RCBO devices can be used in DIN rail enclosures and invicta panelboards.

Dimensions

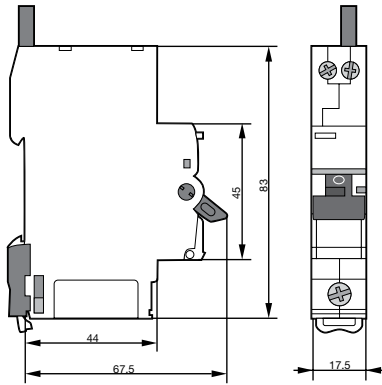

Tripping curve - All In Tcal= 30°C C curve and D curve

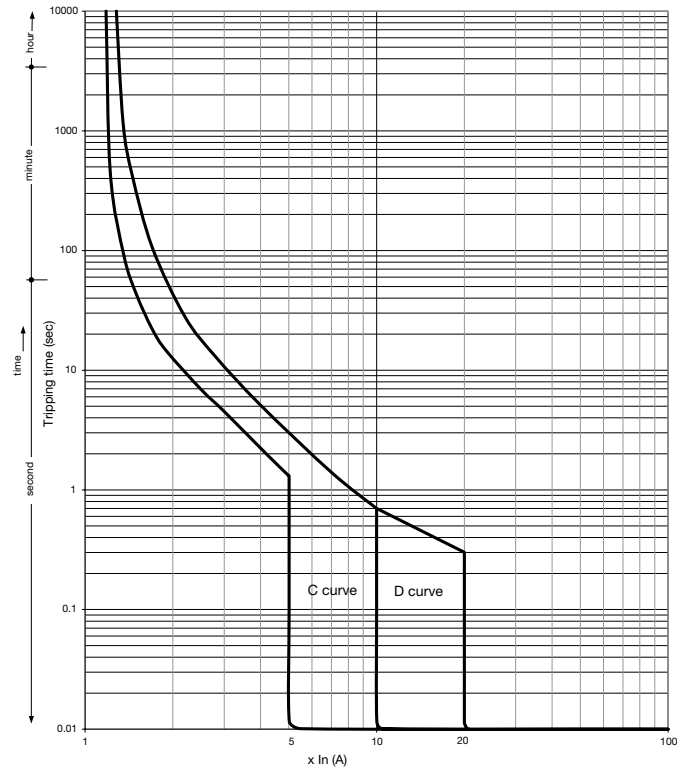

Specifications

Standards	AS/NZS 61009.1
Wave form of earth fault detected	Type A
Residual current tripping technology	Voltage dependent, bi-directional and facility insulation resistance test
Thermal trip characteristic	C curve (5-10 x In) for ADC9xxT and ACC9xxT D curve (10-20 x In) for ADD9xxT
Breaking capacity Icn	6000A
Frequency	50Hz
Voltage rating	230 - 240V AC
Current rating In	6A - 32A for ADC9xxT and ACC9xxT 6A - 25A for ADD9xxT
Residual operating current	30mA for ADC9xxT and ADD9xxT 10mA for ACC9xxT
No. of operations	30,000
Connection capacity	Rigid 16mm ² max. Flexible 10mm ² max.
Tightening torque	2.1Nm bottom and 1.9Nm top
Neutral-IN connectivity	Stranded cable 1m long
Toggle	Sealable Off position
Operating temperature	-25°C to 70°C

Temperature derating table (calibration temperature 30°C)

Ambiant temp (°C)	Rated current (A)						
	6	10	13	16	20	25	32
-25	7.4	12.3	15.9	20.5	25.5	32.4	38.6
-20	7.3	12.1	15.6	20.1	25	31.7	38
-15	7.1	11.9	15.3	19.7	24.5	31.1	37.4
-10	7	11.7	15.1	19.3	24	30.4	36.8
-5	6.9	11.5	14.8	18.9	23.5	29.7	36.2
0	6.8	11.3	14.6	18.5	23	29	35.6
5	6.6	11.1	14.3	18.1	22	28.4	35
10	6.5	10.8	14.1	17.6	23.2	27.7	34.4
15	6.4	10.6	13.8	17.2	21.5	27	33.8
20	6.3	10.4	13.5	16.8	21	26.3	33.2
25	6.1	10.2	13.3	16.4	20.5	25.7	32.6
30	6	10	13	16	20	25	32
35	5.9	9.8	12.8	15.7	19.6	24.3	31.3
40	5.7	9.6	12.5	15.5	19.2	23.7	30.7
45	5.6	9.4	12.2	15.2	18.8	23	30
50	5.5	9.2	12	15	18.4	22.3	29.3
55	5.4	9	11.7	14.7	18	21.6	28.6
60	5.2	8.7	11.5	14.5	17.6	21	28
65	5.1	8.5	11.2	14.2	17.2	20.3	27.3
70	5	8.3	11	14	16.8	19.6	26.6

Modular Protection devices

Dimensions

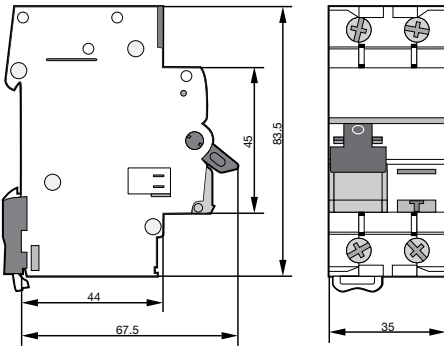

Specifications

Standards	AS/NZS 61009.1
Wave form of earth fault detected	Type A
Residual current tripping technology	Voltage independent, bi-directional and facility insulation resistance test
Thermal trip characteristic	C curve (5-10 x In)
Breaking capacity Icn	6000A
Voltage rating	240V AC
Frequency	50Hz
Current rating	6A - 40A
Residual operating current	30mA for ADA9xxT 100mA for AEA9xxT
Test button operational voltage	Network voltage
No. of operations	4000 for AEA9xxT 2000 for ADA9xxT
Connection capacity	Rigid 25mm ² max. Flexible 16mm ² max.
Tightening torque	2.1 Nm
Neutral-IN connectivity	Neutral in the cage - insulated busbar slot
Toggle	Sealable Off position
Operating temperature	-25°C to 40°C

Tripping curve - All In Tcal= 30°C C curve

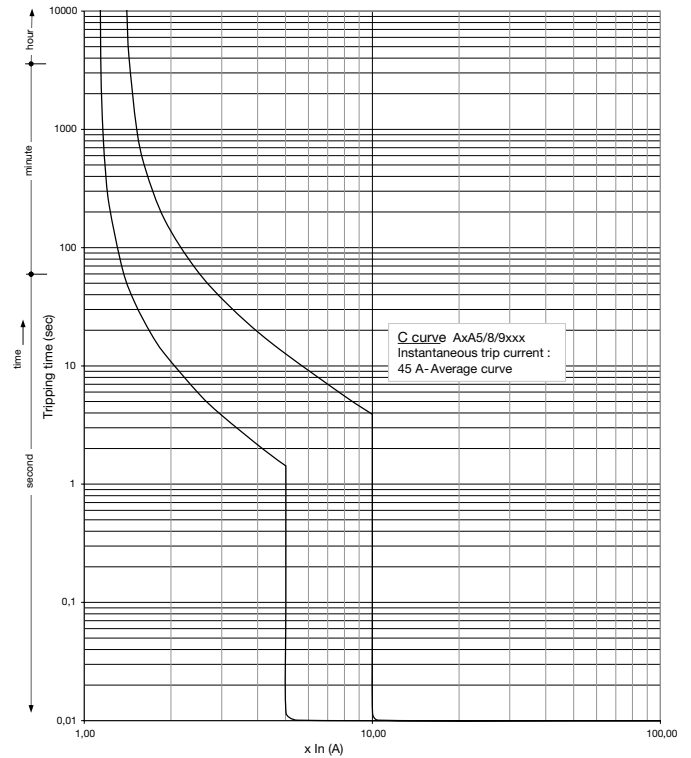

Temperature derating table (calibration temperature 30°C)

Ambiant temp (°C)	Rated current (A)							
	6	10	13	16	20	25	32	40
-25	7.2	12	15.3	18.5	22.7	28.2	38.3	46.9
-20	7.1	11.9	15.1	18.3	22.5	27.9	37.8	46.3
-15	7	11.7	14.9	18.1	22.2	27.6	37.2	45.6
-10	6.9	11.5	14.7	17.9	22	27.4	36.7	45
-5	6.8	11.3	14.5	17.7	21.8	27.1	36.1	44.4
0	6.7	11.1	14.3	17.4	21.5	26.8	35.6	43.8
5	6.6	11	14.1	17.2	21.3	26.5	35	43.1
10	6.5	10.8	13.9	17	21	26.2	34.4	42.5
15	6.4	10.6	13.7	16.7	20.8	25.9	33.8	41.9
20	6.2	10.4	13.5	16.5	20.5	25.6	33.2	41.3
25	6.1	10.2	13.2	16.2	20.3	25.3	32.6	40.6
30	6	10	13	16	20	25	32	40
35	5.9	9.9	12.8	15.8	19.8	24.8	31.5	39.4
40	5.8	9.7	12.6	15.6	19.6	24.5	31	38.8
45	5.7	9.6	12.4	15.4	19.4	24.3	30.5	38.2
50	5.6	9.4	12.2	15.2	19.2	24	30	37.5
55	5.5	9.3	12	15	19	23.8	29.5	36.9
60	5.4	9.1	11.8	14.8	18.8	23.5	29	36.2

These RCBOs may be fed in any position: load and line circuits may be connected top or bottom.

Dimensions

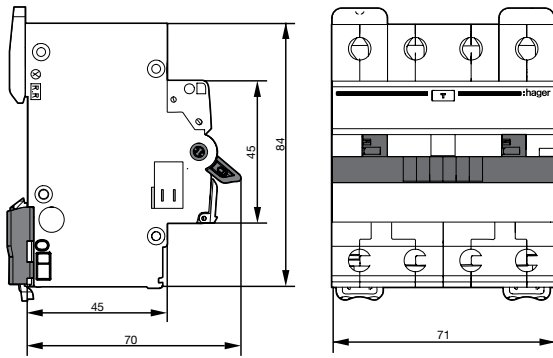

Specifications

Standards	AS/NZS 61009.1
Wave form of earth fault detected	Type A
Residual current tripping technology	Voltage independent, bi-directional and facility insulation resistance test
Thermal trip characteristic	C curve (5-10 x I _n)
Breaking capacity I_{cn}	6000A
Frequency	50Hz
Voltage rating	240 - 415V AC
Current rating	6A - 40A
Residual operating current	30mA for ADM4xxT 100mA for AEM4xxT
Test button operational voltage	375V to 440V
No. of operations	4000
Connection capacity	Rigid 25mm ² max. Flexible 16mm ² max.
Tightening torque	2Nm
Neutral-IN connectivity	Neutral in the cage - insulated neutral busbar slot
Toggle	Sealable On/Off position
Operating temperature	-25°C to 40°C

Tripping curve - Tcal= 30°C C curve

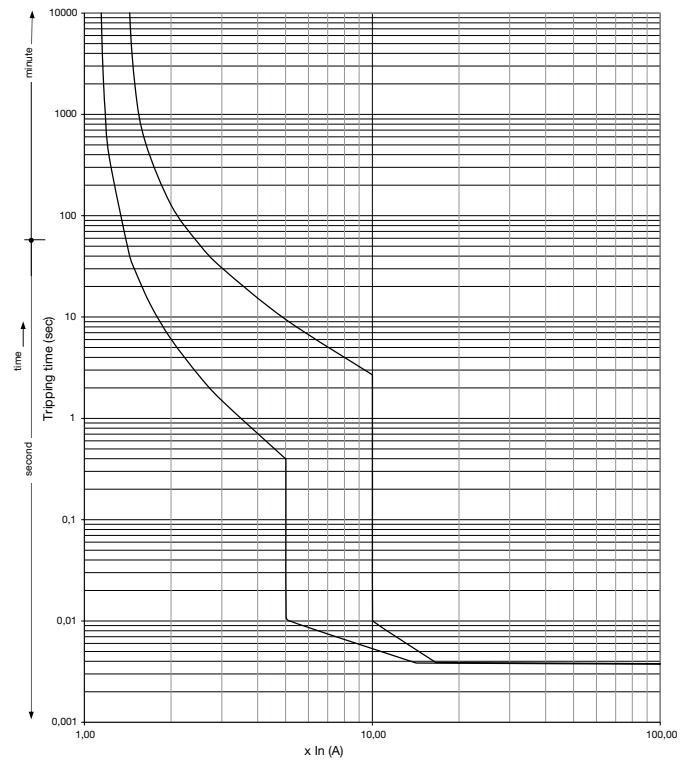

Modular Protection devices

Temperature derating table (calibration temperature 30°C)

Ambiant temp (°C)	Rated current (A)							
	6	10	13	16	20	25	32	40
-25	7.32	12.30	15.51	19.43	23.8	31.7	39.9	49.8
-20	7.21	12.11	15.30	19.14	23.5	31.2	39.3	49
-15	7.10	11.92	15.09	18.85	23.2	30.6	38.6	48.2
-10	6.98	11.72	14.87	18.56	22.9	30	37.9	47.3
-5	6.87	11.52	14.65	18.26	22.5	29.4	37.2	46.5
0	6.75	11.31	14.42	17.95	22.2	28.9	36.5	45.6
5	6.63	11.11	14.20	17.64	21.8	28.3	35.8	44.7
10	6.51	10.89	13.97	17.33	21.5	27.6	35.1	43.8
15	6.39	10.68	13.73	17.00	21.1	27	34.3	42.9
20	6.26	10.46	13.49	16.68	20.8	26.4	33.6	42
25	6.13	10.23	13.25	16.34	20.4	25.7	32.8	41
30	6	10	13	16	20	25	32	40
35	5.86	9.75	12.73	15.62	19.6	24.3	31.2	38.9
40	5.72	9.50	12.45	15.24	19.1	23.6	30.3	37.7
45	5.58	9.24	12.16	14.85	18.6	22.8	29.4	36.5
50	5.43	8.97	11.87	14.44	18.2	22	28.5	35.2
55	5.28	8.69	11.57	14.02	17.7	21.2	27.5	33.9
60	5.12	8.41	11.26	13.59	17.2	20.4	26.5	32.6

Electrical connection - not suitable for single phase circuits

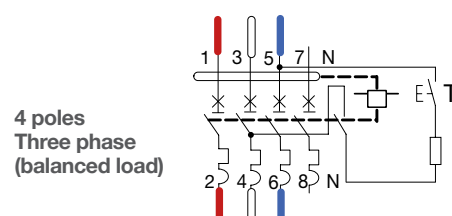
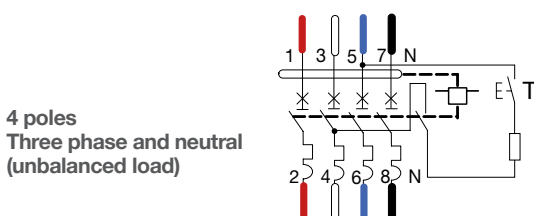

Dimensions

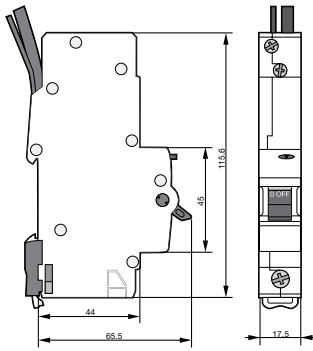

Specifications

Standards	AS/NZS 61009.1
Wave form of earth fault detected	Type A
Residual current tripping technology	Voltage dependent
Thermal trip characteristic	C curve (5-10 x In)
Breaking capacity Icn	6000A and 10,000A
Frequency	50Hz
Voltage rating	240V AC
Current rating	6A - 45A
No. of operations	2000
Connection capacity	Rigid 25mm ² max. Flexible 16mm ² max.
Tightening torque	2.1 Nm
Residual operating current	30mA for ADA1xxT and AD1xxB 10mA for ACA1xxT and AC1xxB
Neutral-IN connectivity	Stranded cable 79cm long
Toggle	Sealable On/Off position
Operating temperature	-5°C to 60°C
Functional Earth	Stranded cable 77cm long

Tripping curve - All In Tcal= 30°C C curve

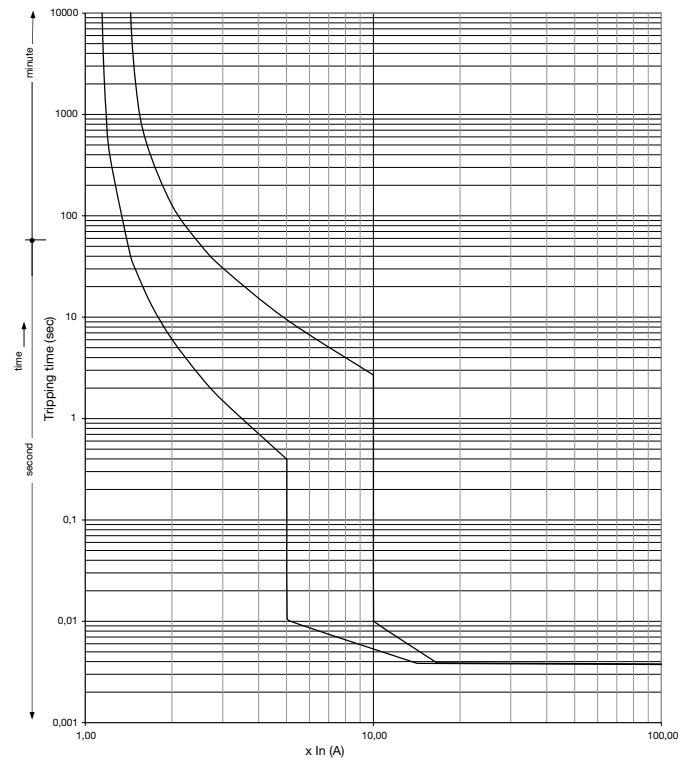

Temperature derating table (calibration temperature 30°C)

Ambiant temp (°C)	Rated current (A)							
	6	10	16	20	25	32	40	45
-25	7.7	13.4	22.2	25.8	31.4	40.1	51.3	53.1
-20	7.6	13.1	21.7	25.3	30.8	39.4	50.3	52.4
-15	7.4	12.8	21.2	24.7	30.3	38.7	49.2	51.8
-10	7.3	12.6	20.7	24.2	29.8	38.0	48.2	51.0
-5	7.1	12.3	20.2	23.7	29.2	37.3	47.2	50.3
0	7.0	12.0	19.6	23.2	28.6	36.6	46.2	49.6
5	6.8	11.7	19.1	22.6	28.1	35.9	45.1	48.9
10	6.7	11.4	18.5	22.1	27.5	35.1	44.1	48.1
15	6.5	11.0	17.9	21.6	26.9	34.4	43.1	47.4
20	6.4	10.7	17.3	21.1	26.3	33.6	42.1	46.6
25	6.2	10.4	16.7	20.5	25.6	32.8	41.0	45.8
30	6	10	16	20	25	32	40	45
35	5.8	9.6	15.4	19.6	24.3	31.2	39.1	44.2
40	5.6	9.3	14.8	19.2	23.7	30.3	38.2	43.4
45	5.4	8.9	14.1	18.8	23.0	29.4	37.3	42.5
50	5.2	8.4	13.5	18.4	22.2	28.5	36.4	41.6
55	5.0	8.0	12.9	18.0	21.5	27.6	35.5	40.8
60	4.8	7.5	12.3	17.6	20.7	26.6	34.6	39.9

Dimensions

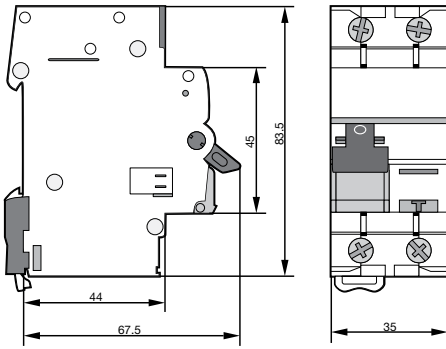

Specifications

Standards	AS/NZS 61009.1
Wave form of earth fault detected	Type A
Residual current tripping technology	Voltage independent, bi-directional and facility insulation resistance test
Thermal trip characteristic	C curve (5-10 x I _n)
Breaking capacity I_{cn}	10,000A
Voltage rating	240V AC
Frequency rating	50Hz
Current rating	6A - 32A
Residual operating current	10mA for ACA5xxT 30mA for ADA5xxT
Test button operational voltage	375V to 440V
No. of operations	2000
Connection capacity	Rigid 25mm ² max. Flexible 16mm ² max.
Tightening torque	2.1 Nm
Toggle	Sealable Off position
Operating temperature	-25°C to 40°C

Tripping curve - All In Tcal= 30°C C curve

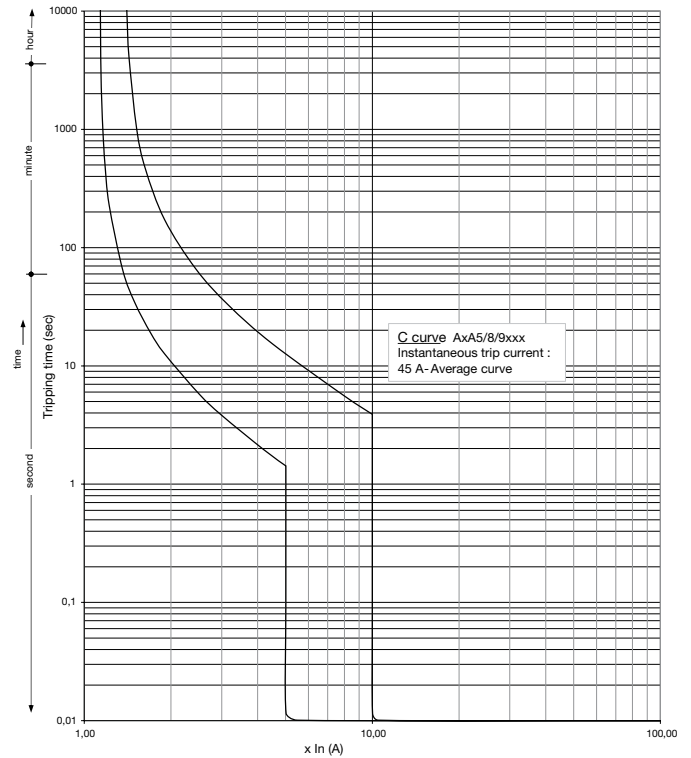

Temperature derating table (calibration temperature 30°C)

Ambiant temp (°C)	Rated current (A)						
	6	10	13	16	20	25	32
-25	7.23	12.02	15.33	18.53	22.69	28.19	38.30
-20	7.13	11.85	15.13	18.31	22.46	27.91	37.77
-15	7.03	11.68	14.93	18.10	22.23	27.64	37.24
-10	6.92	11.50	14.73	17.88	21.99	27.36	36.69
-5	6.81	11.33	14.53	17.65	21.75	27.07	36.14
0	6.70	11.15	14.32	17.43	21.51	26.79	35.58
5	6.59	10.97	14.11	17.20	21.27	26.50	35.01
10	6.48	10.78	13.89	16.97	21.02	26.21	34.43
15	6.36	10.59	13.68	16.73	20.77	25.91	33.84
20	6.24	10.40	13.45	16.49	20.52	25.61	33.24
25	6.12	10.20	13.23	16.25	20.26	25.31	32.63
30	6	10	13	16	20	25	32
35	5.90	9.86	12.81	15.80	19.80	24.76	31.52
40	5.80	9.71	12.62	15.61	19.60	24.52	31.03
45	5.70	9.56	12.42	15.41	19.39	24.27	30.54
50	5.60	9.41	12.23	15.20	19.18	24.02	30.03
55	5.49	9.26	12.03	15.00	18.98	23.77	29.52
60	5.38	9.10	11.82	14.79	18.76	23.52	29.00

These RCBOs may be fed in any position: load and line circuits may be connected top or bottom.

Modular Protection devices

Dimensions

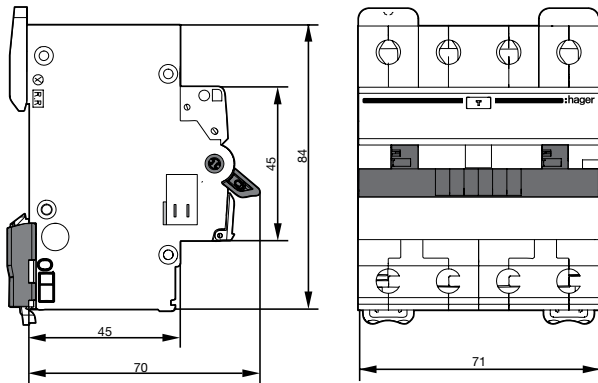

Specifications

Standards	AS/NZS 61009.1
Wave form of earth fault detected	Type A
Residual current tripping technology	Voltage independent, bi-directional and facility insulation resistance test
Thermal trip characteristic	C curve (5-10 x In)
Breaking capacity Icn	10,000A
Voltage rating	240 - 415V AC
Frequency	50Hz
Current rating	6A - 40A
Residual operating current	30mA for ADX4xxT 100mA for AEX4xxT
Test button operational voltage	375V to 440V
No. of operations	4000
Connection capacity	Rigid 25mm ² max. Flexible 16mm ² max.
Tightening torque	2Nm
Neutral-IN connectivity	Neutral in the cage - insulated neutral busbar slot
Toggle	Sealable On/Off position
Operating temperature	-25°C to 40°C

Tripping curve - Tcal= 30°C C curve

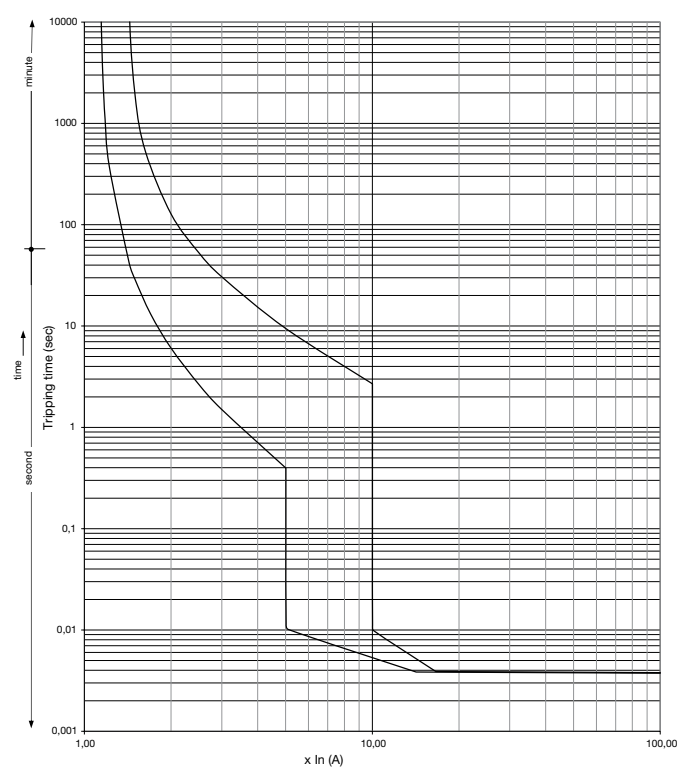

Temperature derating table (calibration temperature 30°C)

Ambiant temp (°C)	Rated current (A)							
	6A	10A	13A	16A	20A	25A	32A	40A
-25	7.32	12.30	15.51	19.43	23.83	31.71	39.90	49.79
-20	7.21	12.11	15.30	19.14	23.51	31.16	39.25	48.98
-15	7.10	11.92	15.09	18.85	23.18	30.60	38.59	48.16
-10	6.98	11.72	14.87	18.56	22.85	30.03	37.91	47.32
-5	6.87	11.52	14.65	18.26	22.52	29.44	37.23	46.47
0	6.75	11.31	14.42	17.95	22.17	28.85	36.52	45.60
5	6.63	11.11	14.20	17.64	21.83	28.25	35.81	44.72
10	6.51	10.89	13.97	17.33	21.47	27.63	35.08	43.81
15	6.39	10.68	13.73	17.00	21.11	26.99	34.34	42.89
20	6.26	10.46	13.49	16.68	20.75	26.35	33.58	41.95
25	6.13	10.23	13.25	16.34	20.38	25.68	32.80	40.99
30	6	10	13	16	20	25	32	40
35	5.86	9.75	12.73	15.62	19.56	24.29	31.15	38.86
40	5.72	9.50	12.45	15.24	19.10	23.56	30.28	37.69
45	5.58	9.24	12.16	14.85	18.63	22.81	29.39	36.48
50	5.43	8.97	11.87	14.44	18.16	22.04	28.46	35.23
55	5.28	8.69	11.57	14.02	17.66	21.23	27.51	33.93
60	5.12	8.41	11.26	13.59	17.16	20.39	26.52	32.58

ADX4xxT / AEX4xxT electrical connection - not suitable for single phase circuits

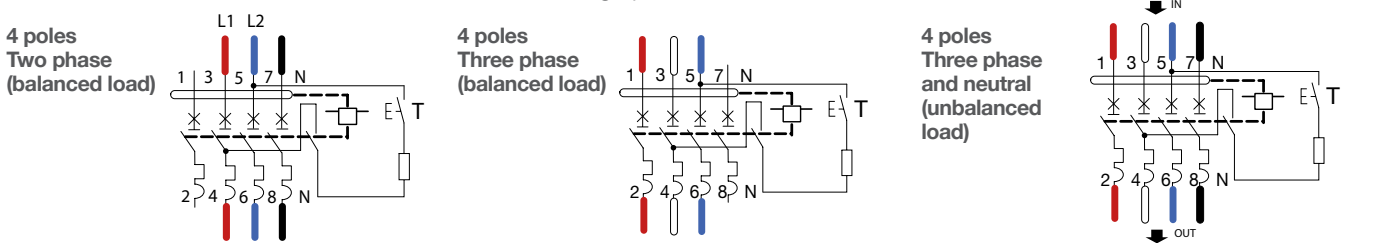

Electrical Connection

RCCB load and line circuits may be connected top or bottom.

2 poles

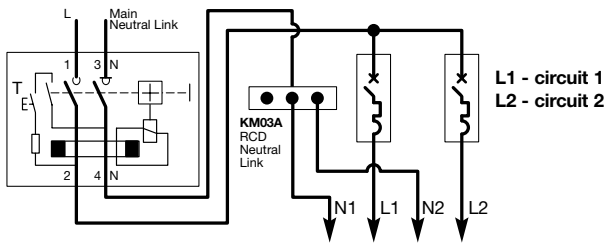

Dimensions

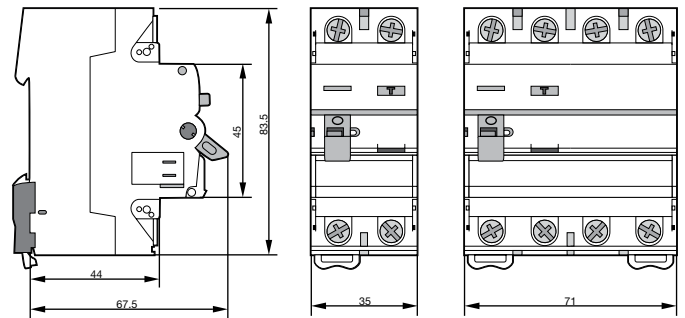

4 poles (CDA4xxT)

Three phase & neutral
(unbalanced load)

Three phase
(balanced load)

Single phase
Two circuits

Single phase
Three circuits
common neutral

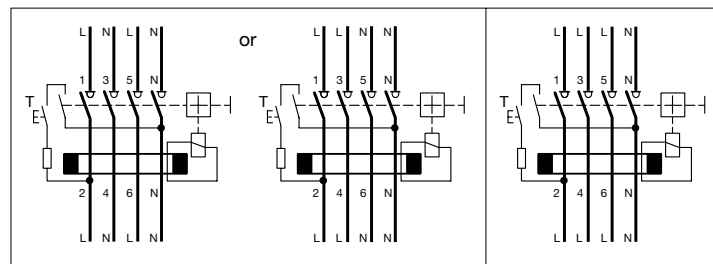
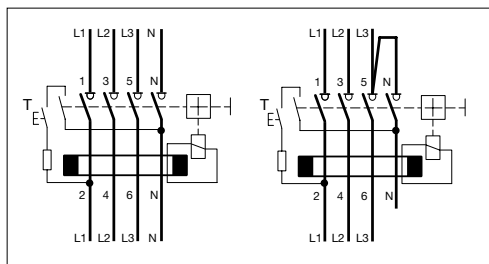

4 poles (CxA5xxT, CxA6xxT & CDFxxxT)

Three phase & neutral use

Three phase use, no neutral

Single phase use
Two circuits

One circuit

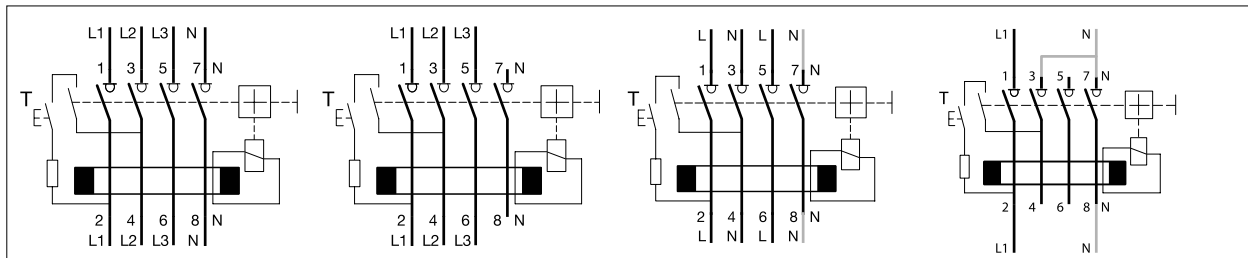

Specifications

	CDA2xxT	CDA4xxT	CxA5xxT	CxA6xxT	CDF5xxT/CDF6xxT
Standards	AS/NZS 61008.1	AS/NZS 61008.1	AS/NZS 61008.1	AS/NZS 61008.1	AS/NZS 61008.1 and IEC62423
Wave form of earth fault current detected	Type A	Type A	Type A	Type A	Type F
Residual current tripping technology	Voltage independent, bi-directional, facility insulation resistance test	Voltage independent, bi-directional, facility insulation resistance test	Voltage independent, bi-directional, facility insulation resistance test	Voltage independent, bi-directional, facility insulation resistance test	Voltage independent, bi-directional, facility insulation resistance test
Voltage rating	2 mod 230V AC		240 AC		230-240V AC
	4 mod	230/400V AC		240/415V AC	230-240/400-415V AC
Frequency	50Hz	50Hz	50Hz	50Hz	50Hz
Current rating	2 mod 25A to 63A - 30mA		80A to 100A - 30mA		40A to 63A - 30mA
	4 mod	25A to 63A - 30mA	25A to 100A - 100mA	80A to 100A - 30mA	40A to 63A 30mA
				25A to 100A - 100mA	
Rated conditional short circuit Inc	6kA	6kA	10kA	10kA	10kA
Test button operational voltage	2 mod 195V to 265V		19w5V to 264V		195V to 264V
	4 mod	195V to 456V		195V to 456V	195V to 456V
Connection capacity	≤ 63A 25mm ² rigid max 16mm ² flexible max	25mm ² rigid max 16mm ² flexible max	25mm ² rigid max 16mm ² flexible max	25mm ² rigid max 16mm ² flexible max	25mm ² rigid max 16mm ² flexible max
	≥ 80A		50mm ² rigid max 35mm ² flexible max	50mm ² flexible max 35mm ² flexible max	
Tightening torque	2.8Nm	2.8Nm	3.6Nm	3.6Nm	3.6Nm
Operating temperature	-25°C to 40°C	-25°C to 40°C	-25°C to 50°C	-25°C to 50°C	-25°C to 70°C
Toggle	Sealable Off position	Sealable Off position	Sealable On/Off position	Sealable On/Off position	Sealable On/Off position

Electrical Connection

Ensure the correct direction of the electrical current.
Supply terminals on top and load terminals on the bottom.

1P+N

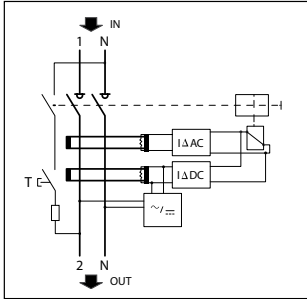

3P+N

Three phase & neutral
(unbalanced load)

Three phase
(balanced load)

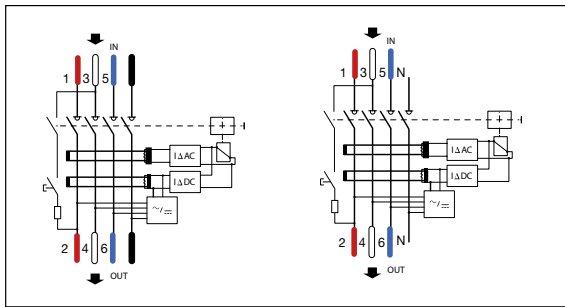

Dimensions

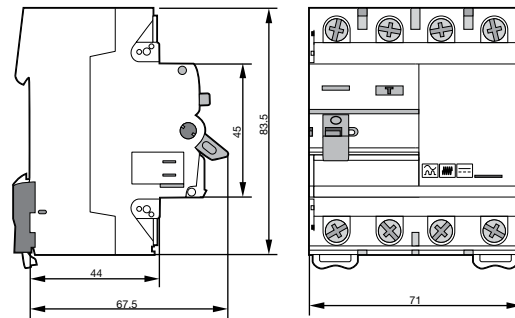

LED indicator

Waveform of leakage current detected:



Not lit



Green

Specifications

	CDBxxxT	
Standards	AS/NZS 61008.1 and IEC62423	
Wave form of earth fault current detected	Type B	
Residual current tripping technology	Voltage independent - disconnect outgoing cables before circuit insulation resistance test.	
Voltage rating	1P+N	230-240V AC
	3P+N	230-240/400-415V AC
Frequency	50Hz	
Current rating	25A to 63A - 30mA	
Rated conditional short circuit <i>I_{nc}</i>	10kA	
Test button operational voltage	195V to 456V	
Connection capacity ≤ 63A	25mm ² rigid max 16mm ² flexible max	
Tightening torque	3.6Nm	
Connectivity	Not suitable for 1P/3P fork busbar	
Operating temperature	-25°C to 70°C	
Toggle	Sealable On-Off position	

	Cat ref.	MSNxxx	NTxxxC	NDNxxxA	HMFxxxT HMCxxxT HMDxxxT	Axx3xxT Ax1xxT Ax1xxB	ADA9xxT	AxA5xxT	AxM4xxT AxX4xxT	CDA2xxT CDA4xxT	Cxx5xxT Cxx6xxT
Switch type		MCB	MCB	MCB	MCB	RCBO	RCBO	RCBO	RCBO	RCCB	RCCB
kA rating		6kA	10kA	10kA	10kA	4.5 & 6kA	6kA	10kA	6 & 10kA	-	-
No. of modules		1/2/3	1/2/3	1/2/3	1.5/3.5/4.5	1	2	2	4	2/4	2/4
Combination auxiliary and alarm contacts	CZ001	-	-	-	-	-	-	-	-	•	-
Heat dissipation inserts	LZ060	•	•	•	•	•	•	•	•	•	•
Auxiliary contacts	MZ201	-	•	•	•	-	-	•	•	With CZ001	•
Alarm contacts	MZ202	-	•	•	•	-	-	•	•	With CZ001	•
Shunt trip relays	MZ203	-	•	•	•	-	-	•	•	•	•
	MZ204	-	•	•	•	-	-	•	•	•	•
Undervoltage releases	MZ206	-	•	•	•	-	-	•	•	•	•
Terminal covers	MZN120	-	-	•	-	-	-	-	-	-	-
	MZN130	-	-	•	-	-	-	-	-	-	-
Phase barriers	MZN121	-	-	•	-	-	-	-	-	-	•
	MZN131	-	-	•	-	-	-	-	-	-	•
Toggle locking device	MZN175	•	•	•	•	•	•	•	•	•	•

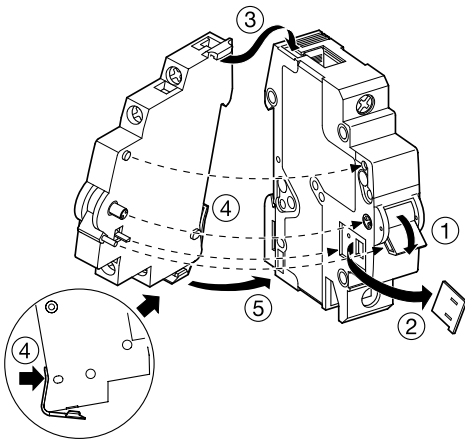

Wiring diagram - MZ201 or MZ202 contact

MZ201 auxiliary contact or MZ 202 Alarm contact

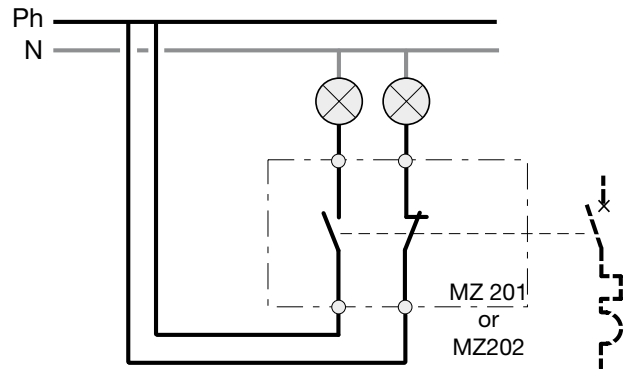

Grouping / combination of several auxiliaries

On compatible 1, 2 and 3 pole MCBs, RCBOs and RCCBs (CxA5xxT and CxA6xxT) it is possible to associate 3 auxiliaries - 2 indication auxiliaries and 1 release auxiliary. In this case, it is important to first fix the indication auxiliary (MZ201 and MZ202) and then the release auxiliary (MZ203, MZ204 and MZ206).

Auxiliary possibilities

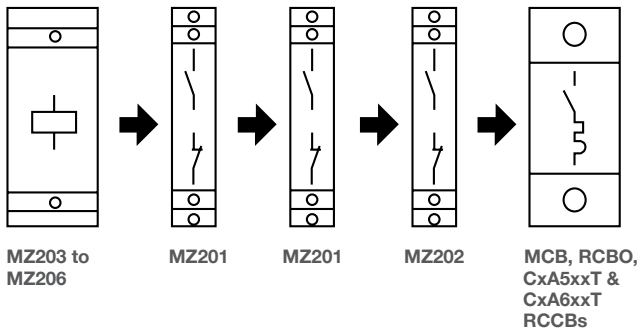

Wiring diagram - MZ203 shunt trip + MZ202 Alarm Contact

An emergency stop button (NO) and a shunt trip - commonly used in automation.

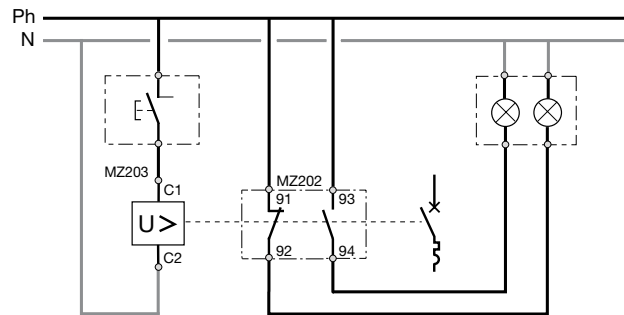

Wiring diagram - MZ206 Undervoltage release + MZ202 Alarm Contact

An emergency stop button (NC) and an undervoltage release. For when positive safety is required. e.g. emergency button.

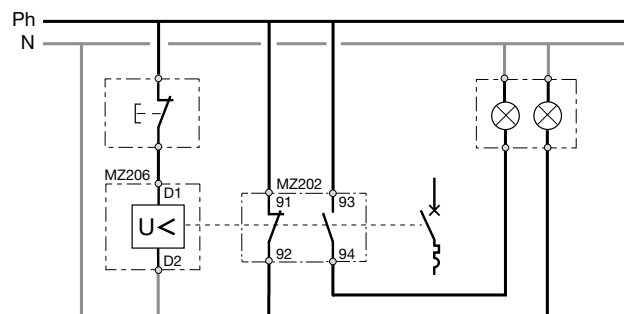

Combination auxiliary and alarm contact

If shunt trip or undervoltage release is required, the CZ001 must be used as a coupler for RCCBs (CDA2xxT and CDA4xxT).

RCCB Auxiliary possibilities

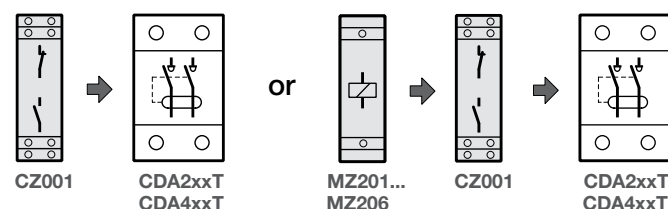

Dimensions

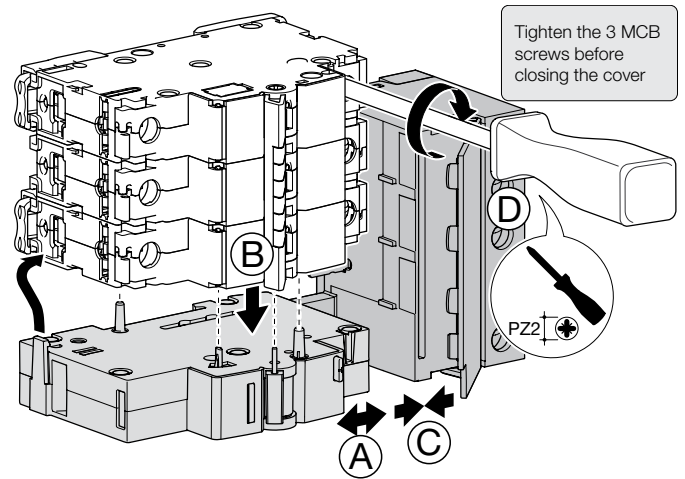
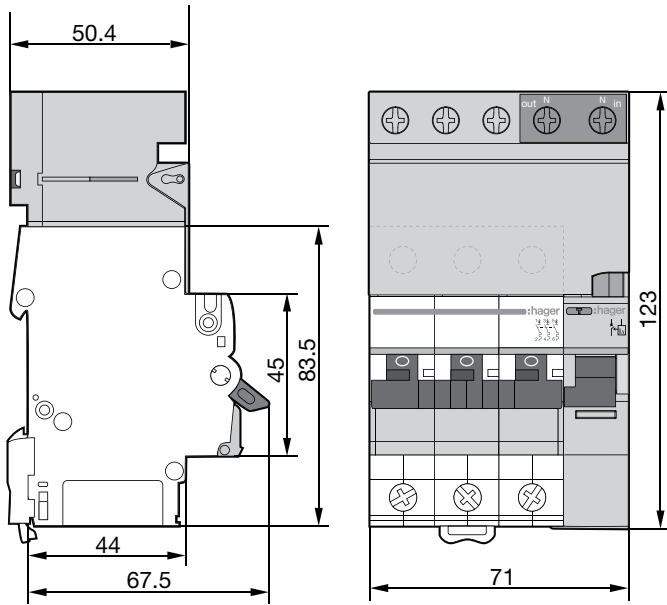

Specifications

Standards	AS/NZS 61008.1
Voltage rating	240/415V AC
Frequency	50Hz
Thermal trip characteristic	C curve (5-10 x I _n) D curve (10-14.4 x I _n)
Current rating	Suitable Add-On for commercial 3 pole MCB's up to 63A (NT, NDN, MSN series).
Test button operational voltage	338V to 457V
No. of operations	1000
Connection capacity	Rigid 25mm ² max. Flexible 16mm ² max.
Tightening torque	3.5Nm
Waveform of earth fault detected	Type A
Residual current technology	Voltage dependent
Residual current	30mA for BD163T 100mA for BE163T 300mA for BF163T
Operating temperature	-5°C to 40°C
Toggle	Sealable OFF position
Breaking capacity I _{cn}	6000A for MSN and MDN range 10,000A for NT and NDN range 15,000A for NDN range

Electrical connection

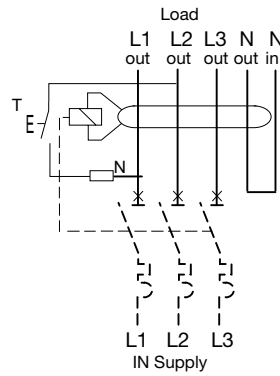

3Ph + N

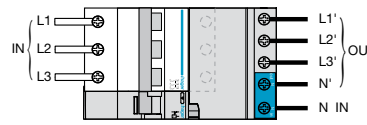

14 mm max.
6 - 40 A : 10 mm²
40 - 63 A : 16 mm²

3Ph

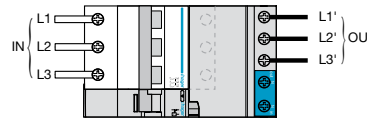

6 - 40 A : 16 mm²
40 - 63 A : 25 mm²

Electrical characteristics

Ref	SPA212A	SPA412A	SPB100R	SPB200R	SPB300R	SPB400R	SPB165R	SPB265R	SPB365R	SPB465R
AS/NZ1768 Location Category	Cat C3	Cat C3	Cat C2	Cat C2	Cat C2	Cat C2	Cat C2	Cat C2	Cat C2	Cat C2
AS/NZ1768: Zone Boundary	LPZ 0A - LPZ 1	LPZ 0A - LPZ 1	LPZ 0A - LPZ 1	LPZ 0A - LPZ 1	LPZ 0A - LPZ 1	LPZ 0A - LPZ 1	LPZ 0A - LPZ 1	LPZ 0A - LPZ 1	LPZ 0A - LPZ 1	LPZ 0A - LPZ 1
EN 61643 SPD Type	T1	T1	T2	T2	T2	T2	T2	T2	T2	T2
IEC 61643-1 SPD Class	I	I	II	II	II	II	II	II	II	II
Single Max impulse (8/20 µs)	I_{max}		100kA	100kA	100kA	100kA	65kA	65kA	65kA	65kA
Nominal discharge current (8/20µs)	I_n		40kA	40kA	40kA	40kA	20kA	20kA	20kA	20kA
Pulse discharge current (10/350µs)	I_{imp}	12.5kA	12.5kA	2.5kA	2.5kA	2.5kA	2.5kA	12.5kA	12.5kA	12.5kA
Max. continuous operating voltage	U_c	255 V AC	255 V AC	320 V AC	320 V AC	320 V AC	320 V AC	320 V AC	320 V AC	320 V AC
Voltage protection (common)	U_p	2.5kV	2.5kV	2kV	2kV	2kV	2kV	1.45kV	1.45kV	1.45kV
Residual current	I_{FE}	<100mA	<100mA	<0.45 mA	<5 µA	<0.45 mA	<5 µA	<0.45 mA	<5 µA	<0.45 mA
Iscrr	-	-	25kA	25kA	25kA	25kA	25kA	25kA	25kA	25kA
Maximum rating MCB for overcurrent protection	125A series / 315A parallel	125A series / 315A parallel	63A "C"	63A "C"	63A "C"	63A "C"	63A "C"	63A "C"	63A "C"	63A "C"
Recommended MCB rating	63A "C"	63A "C"	63A "C"	63A "C"	63A "C"	63A "C"	40A "C"	40A "C"	40A "C"	40A "C"
Max Back-up Fuse	-	-	250A	250A	250A	250A	160A	160A	160A	160A
Recommended Back-up Fuse	-	-	63A to 125A	63A to 125A	63A to 125A	63A to 125A	63A to 125A	63A to 125A	63A to 125A	63A to 125A
Conductor Connection Capacity	Min 1.5mm ² Max 35 mm ²	Min 1.5mm ² Max 35 mm ²	Min 1.5mm ² Max 35 mm ²	Min 1.5mm ² Max 35 mm ²	Min 1.5mm ² Max 35 mm ²	Min 1.5mm ² Max 35 mm ²	Min 1.5mm ² Max 35 mm ²	Min 1.5mm ² Max 35 mm ²	Min 1.5mm ² Max 35 mm ²	Min 1.5mm ² Max 35 mm ²
Operating Temperature	-40...60 °C	-40...60 °C	-40...80 °C	-40...80 °C	-40...80 °C	-40...80 °C	-40...80 °C	-40...80 °C	-40...80 °C	-40...80 °C
Contact for Remote Monitoring	N	N	Y	Y	Y	Y	Y	Y	Y	Y
Number of modules total	4	8	1	2	3	4	1	2	3	4
Single phase	Y	-	Y	Y	-	Y	Y	-	-	Y
Three Phase	-	Y	-	-	Y	-	-	Y	Y	-
TNC	-	-	TNC	-	TNC	-	TNC	-	TNC	-
TNS/TT	-	-	-	TNS/TT	-	TNS/TT	-	TNS/TT	-	TNS/TT
Indication of SPD disconnecter	Green LED on L1, L2, L3	Green LED on L1, L2, L4	Green = Good Red = Bad	Green = Good Red = Bad	Green = Good Red = Bad	Green = Good Red = Bad	Green = Good Red = Bad	Green = Good Red = Bad	Green = Good Red = Bad	Green = Good Red = Bad
L-N Replacement cartridge	-	-	SPB010R	SPB010R	SPB010R	SPB010R	SPB065R	SPB065R	SPB065R	SPB065R
N-PE Replacement cartridge	-	-	-	SPB010N	-	SPB010N	-	SPB065N	-	SPB065N
L-N	-	-	1	1	3	1	1	3	3	1
N-PE	-	-	0	1	0	1	0	1	0	1
Response time	t_A	≤100ns	≤100ns	-	-	-	-	-	-	-
Dimensions: Length, Width, Height	-	-	77.5 x 17.5 x 98.7	77.5 x 35 x 98.7	77.5 x 52.5 x 98.7	77.5 x 70 x 98.7	77.5 x 17.5 x 98.7	77.5 x 35 x 98.7	77.5 x 52.5 x 98.7	77.5 x 70 x 98.7

SPD 'R' model contactor wiring layout has changed for all new SPBxxxR SPDs.

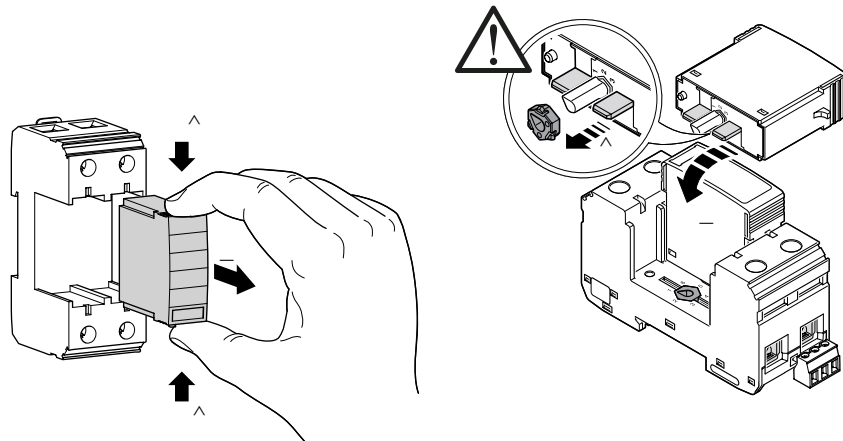
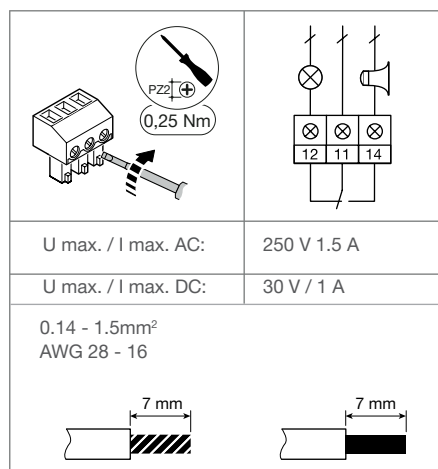

How do I know if I need to replace a SPD cartridge?

- For Very Coarse (100kA) and Coarse (65kA) SPDs - a small oval indicator will change colours from Green (Ok) to Red (Faulty).
- For Medium (40kA) and Fine (8kA) SPDs - a rectangular window is present, when this window is bright red, there is a fault.
- Please note the rectangular style fault indicators may look somewhat red, or red tinged when new.
- If the red 'pin' at the rear of the cartridge is retracted, replace the cartridge. If proud (as pictured to the left), then it is good.

Electrical characteristics

Ref	Medium SPB140D	Medium SPB140R	Medium SPB240D	Medium SPB240R	Medium SPB340D	Medium SPB340R	Medium SPB440D	Medium SPB440R	Fine SPB208D	Fine SPB408D
AS/NZ1768 Location Category	Cat C1 /B	Cat C1 /B	Cat C1 /B	Cat C1 /B	Cat C1 /B	Cat C1 /B	Cat C1 /B	Cat C1 /B	Cat A	Cat A
AS/NZ1768: Zone Boundary	LPZ 1 - LPZ OB	LPZ 1 - LPZ OB	LPZ 1 - LPZ OB	LPZ 1 - LPZ OB	LPZ 1 - LPZ OB	LPZ 1 - LPZ OB	LPZ 1 - LPZ OB	LPZ 1 - LPZ OB	LPZ 2 - LPZ 3	LPZ 2 - LPZ 3
EN 61643 SPD Type	T2	T2	T2	T2	T2	T2	T2	T2	T2	T2
IEC 61643-1 SPD Class	II	II	II	II	II	II	II	II	II	II
Single Max impulse (8/20 µs)	I_{max} 40kA	40kA	40kA	40kA	40kA	40kA	40kA	40kA	8kA	8kA
Nominal discharge current (8/20µs)	I_n 20kA	20kA	20kA	20kA	20kA	20kA	20kA	20kA	2kA	2kA
Pulse discharge current (10/350µs)	I_{imp} -	-	-	-	-	-	-	-	-	-
Max. continuous operating voltage	U_c 275 V AC	275 V AC	275 V AC	275 V AC	275 V AC	275 V AC	275 V AC	275 V AC	275 V AC	275 V AC
Voltage protection (common)	U_p 1.35kV	1.35kV	1.35kV	1.35kV	1.35kV	1.35kV	1.35kV	1.35kV	0.9kV	0.9kV
Residual current	I_{RE} <0.45 mA	<0.45 mA	<5 µA	<5 µA	<0.45 mA	<0.45 mA	<5 µA	<5 µA	<5 µA	<5 µA
Iscrr	25kA	25kA	25kA	25kA	25kA	25kA	25kA	25kA	10kA	10kA
Maximum rating MCB for overcurrent protection	32A "C"	32A "C"	32A "C"	32A "C"	32A "C"	32A "C"	32A "C"	32A "C"	32A "C"	32A "C"
Recommended MCB rating	32A "C"	32A "C"	32A "C"	32A "C"	32A "C"	32A "C"	32A "C"	32A "C"	32A "C"	32A "C"
Max Back-up Fuse	125A	125A	125A	125A	125A	125A	125A	125A	125A	125A
Recommended Back-up Fuse	32A to 100A	32A to 100A	32A to 100A	32A to 100A	32A to 100A	32A to 100A	32A to 100A	32A to 100A	20A to 32A	20A to 32A
Connection Capacity	Min 1.5mm ² Max 35 mm ²	Min 1.5mm ² Max 35 mm ²	Min 1.5mm ² Max 35 mm ²	Min 1.5mm ² Max 35 mm ²	Min 1.5mm ² Max 35 mm ²	Min 1.5mm ² Max 35 mm ²	Min 1.5mm ² Max 35 mm ²	Min 1.5mm ² Max 35 mm ²	Min 1.5mm ² Max 35 mm ²	Min 1.5mm ² Max 35 mm ²
Operating Temperature	-40...80 °C	-40...80 °C	-40...80 °C	-40...80 °C	-40...80 °C	-40...80 °C	-40...80 °C	-40...80 °C	-40...80 °C	-40...80 °C
Contact for Remote Monitoring	N	Y	N	Y	N	Y	N	Y	N	N
Number of modules total	1	1	2	2	3	3	4	4	2	4
Single phase	Y	Y	Y	Y	-	-	-	-	Y	-
Three Phase	-	-	-	-	Y	Y	Y	Y	-	Y
TNC	TNC	TNC	-	-	TNC	TNC	-	-	-	-
TNS/TT	-	-	TNS/TT	TNS/TT	-	-	TNS/TT	TNS/TT	TNS/TT	TNS/TT
Indication of SPD disconnecter	Bright Red = Replace	Bright Red = Replace	Bright Red = Replace	Bright Red = Replace	Bright Red = Replace	Bright Red = Replace	Bright Red = Replace	Bright Red = Replace	Bright Red = Replace	Bright Red = Replace
L-N Replacement cartridge	SPB040D	SPB040D	SPB040D	SPB040D	SPB040D	SPB040D	SPB040D	SPB040D	SPB008D	SPB008D
N-PE Replacement cartridge	-	-	SPB040N	SPB040N	-	-	SPB040N	SPB040N	SPB040N	SPB040N
L-N	1	1	1	1	3	3	3	3	1	3
N-PE	0	0	1	1	0	0	1	1	1	1
Dimensions: Length, Width, Height	65.7 x 17.5 x 98.7	65.7 x 17.5 x 98.7	65.7 x 35 x 98.7	65.7 x 35 x 98.7	65.7 x 52.5 x 98.7	65.7 x 52.5 x 98.7	65.7 x 70 x 98.7	65.7 x 70 x 98.7	58 x 35 x 90	65.7 x 70 x 90

SPD 'R' model contactor wiring layout has changed for all new SPBxxxR SPDs.

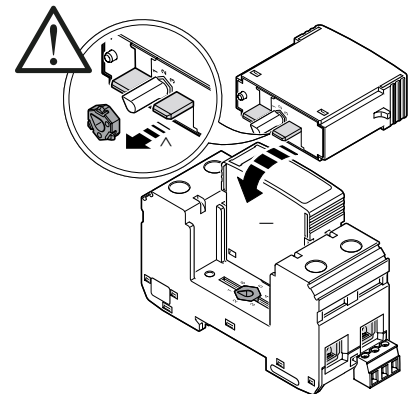
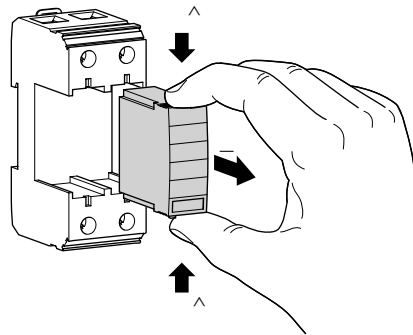
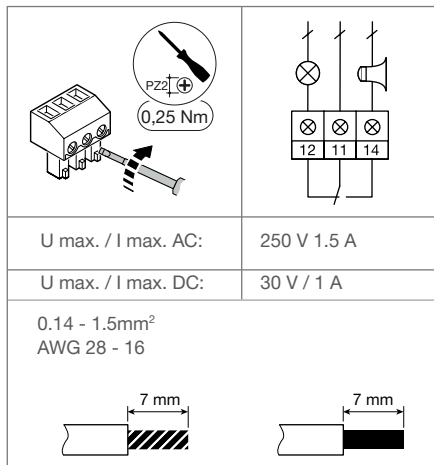

How do I know if I need to replace a SPD cartridge?

- For Very Coarse (100kA) and Coarse (65kA) SPDs - a small oval indicator will change colours from Green (Ok) to Red (Faulty).
- For Medium (40kA) and Fine (8kA) SPDs - a rectangular window is present, when this window is bright red, there is a fault.
- Please note the rectangular style fault indicators may look somewhat red, or red tinged when new.
- If the red 'pin' at the rear of the cartridge is retracted, replace the cartridge. If proud (as pictured to the left), then it is good.

Electrical characteristics

Ref		Very Coarse	Very Coarse	Coarse	Coarse	Medium	Medium	Fine
		SPB010R	SPB010N	SPB065R	SPB065N	SPB040D	SPB040N	SPB008D
AS/NZ1768 Location Category		Cat C3	Cat C3	Cat C2	Cat C2	Cat C1/B	Cat C1/B	Cat CA
AS/NZ1768: Zone Boundary		LPZ 0A - LPZ 1	LPZ 0A - LPZ 1	LPZ 0A - LPZ 1	LPZ 0A - LPZ 1	LPZ 1 - LPZ OB	LPZ 1 - LPZ OB	LPZ 2 - LPZ 3
EN 61643 SPD Type		T1	T1	T2	T2	T2	T2	T2
IEC 61643-1 SPD Class		I	I	II	II	II	II	II
Single Max impulse (8/20 μs)	I_{max}	100kA	100kA	65kA	65kA	40kA	40kA	8kA
Nominal discharge current (8/20 μs)	I_n	40kA	40kA	20kA	20kA	20kA	20kA	2kA
Pulse discharge current (10/350 μs)	I_{imp}	2.5kA	2.5kA	-	-	-	-	-
Max. continuous operating voltage	U_c	320 V AC	260 V AC	275 V AC	260 V AC	275 V AC	260 V AC	275 V AC
Voltage protection (common)	U_p	2kV	1.5kV	1.35kV	1.5kV	1.35kV	1.5kV	0.9kV
Residual current	I_{FE}	-	-	-	-	-	-	-
Isccr		-	-	-	-	-	-	-
Maximum rating MCB for overcurrent protection		-	-	-	-	-	-	-
Recommended MCB rating		-	-	-	-	-	-	-
Max Back-up Fuse		-	-	-	-	-	-	-
Recommended Back-up Fuse		-	-	-	-	-	-	-
Connection Capacity		-	-	-	-	-	-	-
Operating Temperature		-40...80 °C	-40...80 °C	-40...80 °C	-40...80 °C	-40...80 °C	-40...80 °C	-40...80 °C
Remote Contact		-	-	-	-	-	-	-
Number of modules total		1	1	1	1	1	1	1
Single phase		-	-	-	-	-	-	-
Three Phase		-	-	-	-	-	-	-
TNC		-	-	-	-	-	-	-
TNS/TT		-	-	-	-	-	-	-
Indication of SPD disconnect		Green = good Red = replace	Green = good Red = replace	Green = good Red = replace	Green = good Red = replace	Bright Red = Replace	Bright Red = Replace	Bright Red = Replace
L-N Replacement cartridge		-	-	-	-	-	-	-
N-PE Replacement cartridge		-	-	-	-	-	-	-
L-N		1 x L-N	-	1 x L-N	-	1 x L-N	-	1 x L-N
N-PE		-	1 x N-PE	-	1 x N-PE	-	1 x N-PE	-

Modular Protection devices

Very Coarse and Coarse SPDs

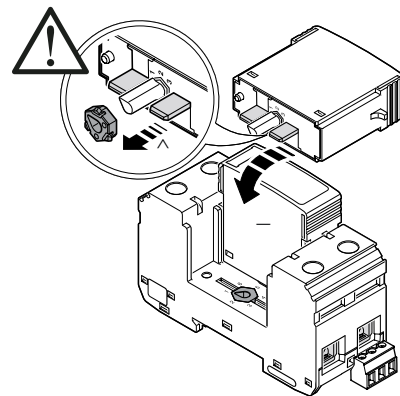
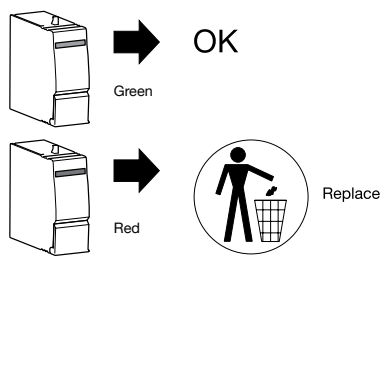

Medium and Fine SPDs

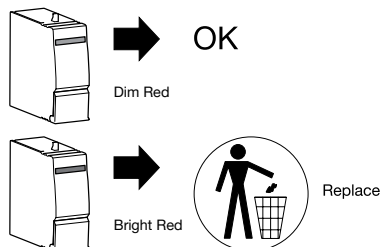

The indicator circled on the left shows this cartridge needs to be replaced, the cartridge not circled to the right of it is ok.

Surge protection single phase layout example in Main switchboard with MEN link

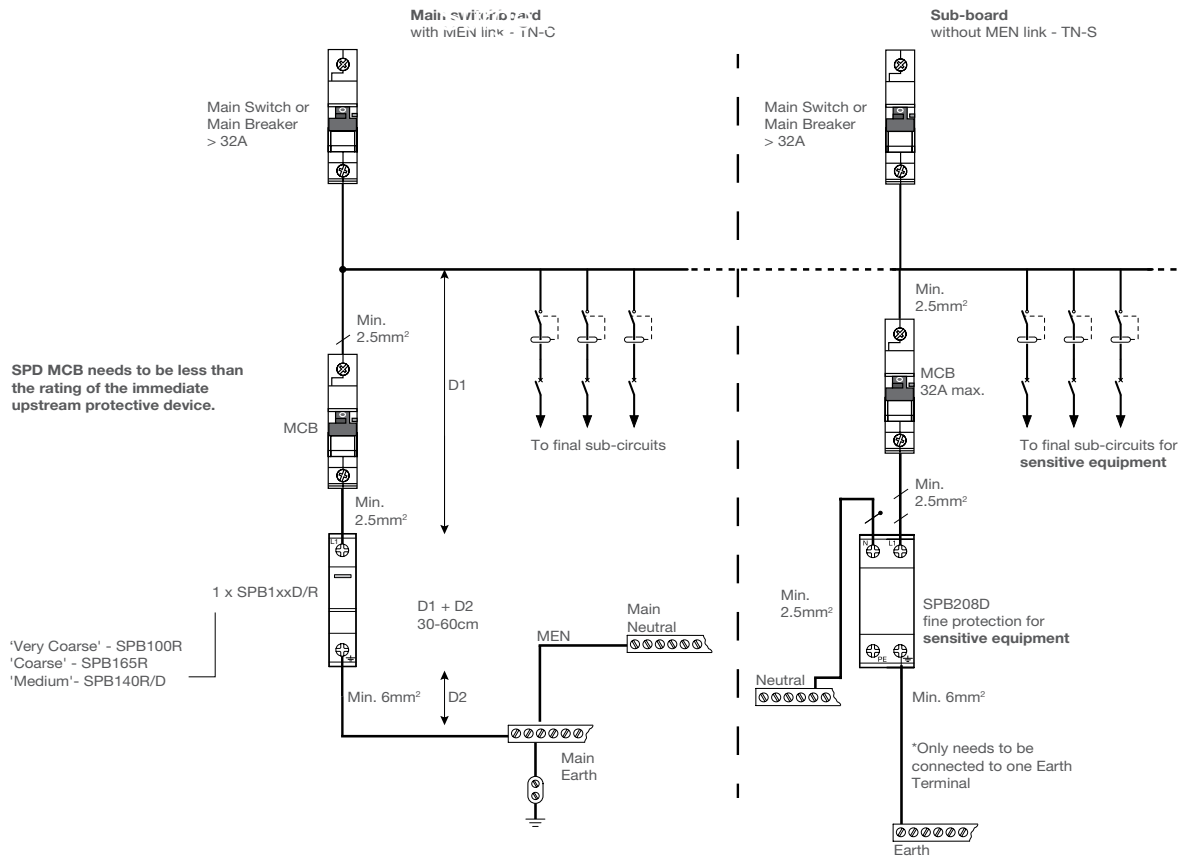

Surge protection single phase layout example in sub-board without MEN link

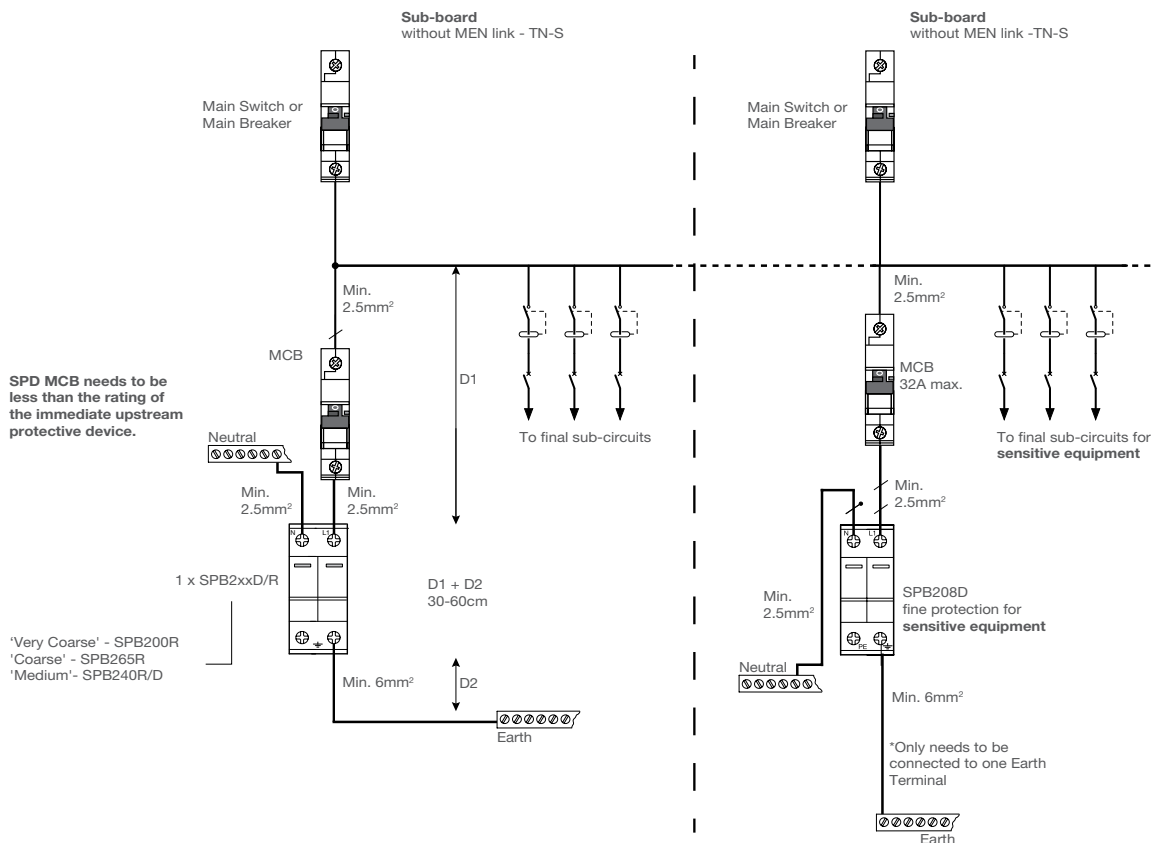

Surge protection three phase layout example in Main switchboard with MEN link

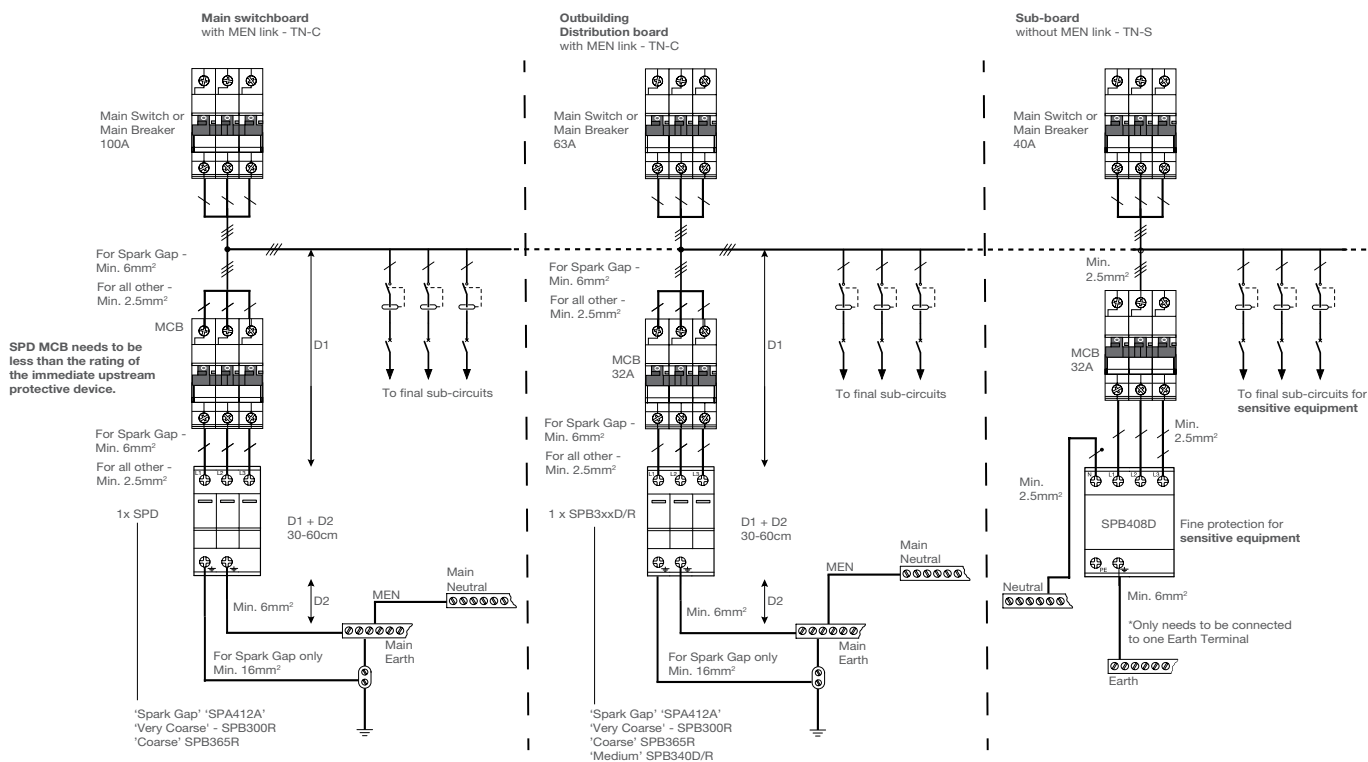

Surge protection three phase layout example in sub-board without MEN link

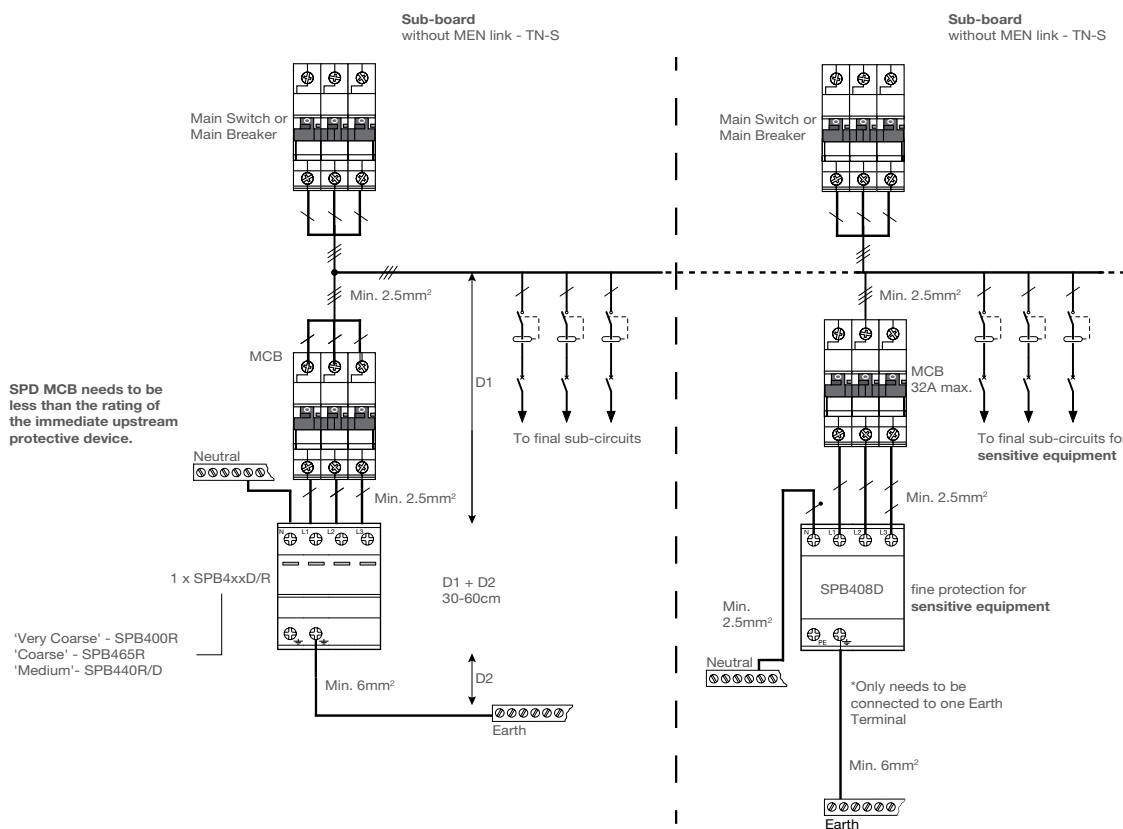

		Upstream					
		Lawson ME & MF BS88 part 3 (BS 1361) IEC/EN 60269-2 80kA, 415 VAC (House Service)					
Downstream	Device	Curve	In (A)	50	63	80	100
		AxA9 6kA IEC 61009	C	10	80	80	6
13				80	80	6	6
16				80	80	6	6
20				80	80	6	6
25				80	80	40	6
32				80	80	40	6
AxA5 10kA IEC 61009		C	10	80	80	10	10
			13	80	80	10	10
			16	80	80	80	10
			20	80	80	80	10
			25	80	80	80	80
			32	80	80	80	80
ADC9 6kA IEC 61009		C	10	80	80	6	6
			13	80	80	6	6
			16	80	80	6	6
			20	80	80	80	6
			25	80	80	80	6
			32				
ADC3 6kA IEC 61009		C	25	80	80	80	6
			32				
AD1 & ADA1 10kA IEC 61009		C	Up to 32A	80	80	80	80
NT 10kA IEC 60898		C	Up to 63A	80	80	80	80
MSN 6kA IEC 60898		C	Up to 63A	80	80	35	20
NDN 10kA IEC 60898		D	6	80	80	80	10
			10	80	80	80	10
			16	80	80	80	10
			20	80	80	80	80
			25	80	80	80	80
			32	80	80	80	80
			40	80	80	80	80
			50	80	80	80	80
HMF 10kA IEC 60898		C	80	-	-	80	80
	100		-	-	-	80	
	125		-	-	-	-	
HMC 15kA IEC 60898	C	80	-	-	80	80	
		100	-	-	-	80	
		125	-	-	-	-	
HMD 15kA IEC 60898	D	80	-	-	80	80	
		100	-	-	-	80	
		125	-	-	-	-	

Breaking capacity according to IEC 60947-2

Network: 230/240 - 400/415 VAC

Notes: « T » = total selectivity (up to the breaking capacity of the downstream device)

« - » = no selectivity

		Upstream					
		Lawson ME & MF BS88 part 3 (BS 1361) IEC 60269 80kA, 415 VAC (House Service)					
Device	Curve	In (A)	50	63	80	100	
AxA9 6kA IEC 61009	C	10	1.83	4.32	T	T	
		13	1.78	4.18	T	T	
		16	1.7	3.66	T	T	
		20	1.35	2.69	T	T	
		25	-	2.75	5.85	T	
		32	-	-	4.93	T	
		40	-	-	-	T	
AxA5 10kA IEC 61009	C	6	3.2	8.78	T	T	
		10	1.83	4.32	T	T	
		13	1.78	4.18	T	T	
		16	1.7	3.66	9.08	T	
		20	1.35	2.69	6.23	T	
		25	-	2.75	5.85	T	
		32	-	-	4.93	7.33	
40	-	-	-	6.93			
ADC9 6kA IEC 61009	C	10	1.45	3.5	T	T	
		13	1.3	3	T	T	
		16	1.2	2.65	T	T	
		20	1.1	2.4	5.4	T	
		25	1	1.9	3.8	T	
ADC3 6kA IEC 61009	C	25	1	1.9	3.8	T	
		32					
AD1 and ADA1 10kA IEC 61009	C	10	1.3	2.5	5.43	T	
		16	1.11	2.08	4.31	8.45	
		20	0.92	1.71	3.31	6.07	
		25	0.92	1.71	3.31	6.07	
32	0.79	1.44	2.75	4.82			

		Upstream					
		Lawson ME & MF BS88 part 3 (BS 1361) IEC 60269 80kA, 415 VAC (House Service)					
Device	Curve	In (A)	50	63	80	100	
NT 10kA IEC 60898	C	2	3.04	8.27	T	T	
		4	2.1	5.22	T	T	
		6	1.7	3.48	7.63	T	
		10	1.54	3.04	6.48	T	
		13	1.28	2.58	5.42	T	
		16	1.26	2.56	5.42	T	
		20	1.08	2.16	4.27	8.5	
		25	1.08	2.16	4.27	8.5	
		32	0.94	1.81	3.38	6.62	
		40	-	1.81	3.38	6.62	
		50	-	-	3.04	5.36	
		63	-	-	-	5.36	
		MSN 6kA IEC 60898	C	6	1.37	2.7	5.59
10	1.17			2.22	4.34	T	
13	0.98			1.86	3.62	T	
16	0.98			1.86	3.62	T	
20	0.82			1.57	3.05	5.95	
25	0.82			1.57	3.05	5.95	
32	0.71			1.45	2.82	5.39	
40	-			1.45	2.82	5.39	
50	-			-	2.58	4.86	
63	-			-	-	4.86	
NDN 10kA IEC 60898	D	6	1.45	3.58	9.5	T	
		10	1.36	2.9	6.5	T	
		16	-	2.31	4.83	T	
		20	-	-	4.2	7.5	
		25	-	-	-	6.5	
		32	-	-	-	5.29	
		40	-	-	-	-	
HMF 10kA IEC 60898	C	80	-	-	-	2.3	
		100	-	-	-	0.7	
		125	-	-	-	-	
HMC 15kA IEC 60898	C	80	-	-	-	2.3	
		100	-	-	-	0.7	
		125	-	-	-	-	
HMD 15kA IEC 60898	D	80	-	-	-	0.75	
		100	-	-	-	-	
		125	-	-	-	-	

Hager e-cat app

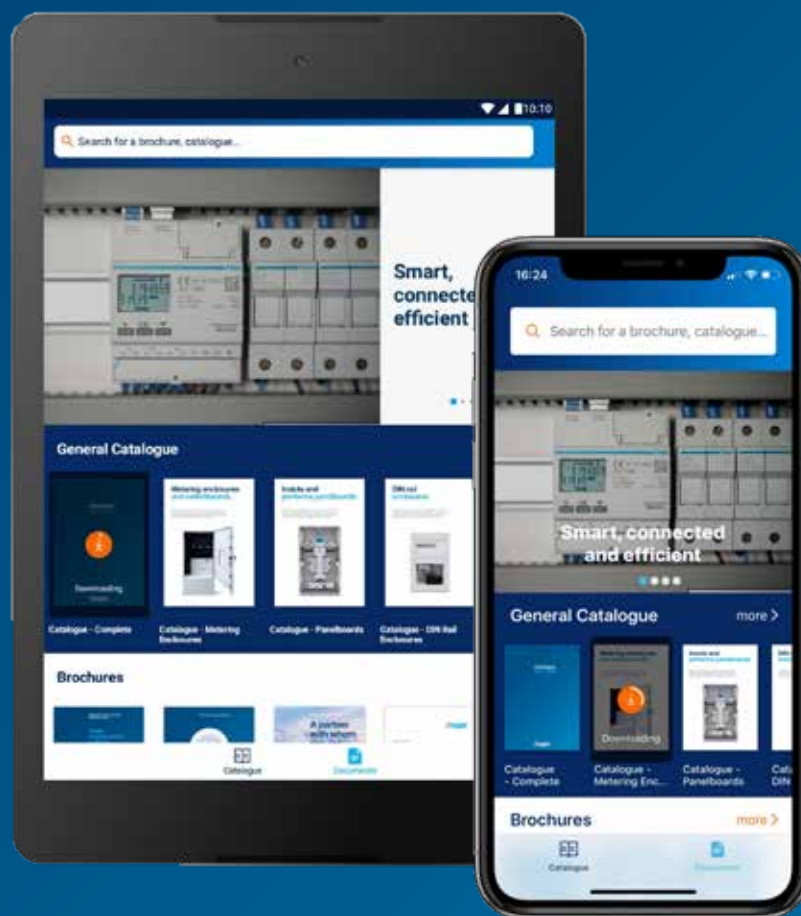

Information on the go

Access all product information on Hager products: product catalogue, technical data and specifications, brochures and more... at your fingertips.

